

ANELLI
RINGS

20-001 | 173
20-002 | 175
20-003 | 175
20-004 | 175
20-005 | 175
20-006 | 175
20-007 | 175
20-008 | 175

20-009 | 175
20-010 | 175
20-011 | 175
20-013 | 174
J001 | 172
J029 | 176
J030 | 176
J031 | 176

J032 | 176
J033 | 176
J034 | 176
J035 | 176
J070 | 176
J071 | 176
J072 | 176
J085 | 173

J094 | 176
J099 | 176
J100 | 176
J107 | 172
J113 | 174
J120 | 171
J121 | 171
J122 | 171

The background is a textured, aged parchment or leather surface in shades of tan and brown. A prominent, irregular tear runs vertically down the left side of the page, revealing a darker, reddish-brown layer underneath. The surface is covered in fine cracks and creases, giving it an antique appearance.

ANELLI
RINGS



Lettura misure:

Measurement legenda:

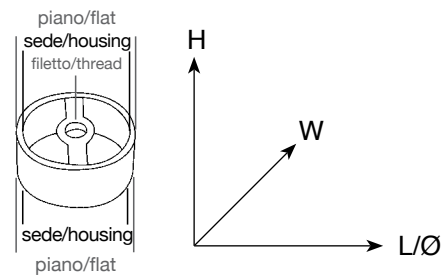

N.B. quota sedi specificata in NERO/
housing dimension in BLACK

L= Lunghezza/Length

H= Altezza/Height

W= Larghezza/Width

Ø= Diametro/Diameter

Fori/holes Ø10,5

xxxxx = senza fori/without holes

xxxxx-01 = 1 foro/hole

xxxxx-02 = 2 fori/holes

xxxxx-03 = 3 fori/holes

xxxxx-04 = 4 fori/holes

xxxxx-05 = 5 fori/holes

xxxxx-06 = 6 fori/holes

xxxxx-08 = 8 fori/holes

xxxxx-10 = 10 fori/holes

xxxxx-12 = 12 fori/holes

xxxxx-30 = senza fori/without holes 3 righe/ruls

xxxxx-31 = 1 foro/hole 3 righe/ruls

xxxxx-32 = 2 fori/holes 3 righe/ruls

xxxxx-33 = 3 fori/holes 3 righe/ruls

xxxxx-36 = 6 fori/holes 3 righe/ruls

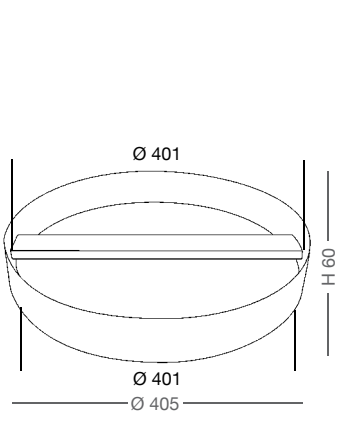

J120
Ø405 x H60

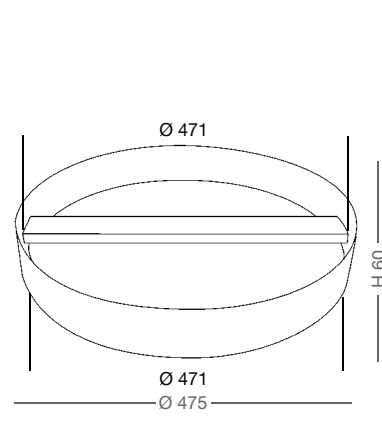

J121
Ø475 x H60

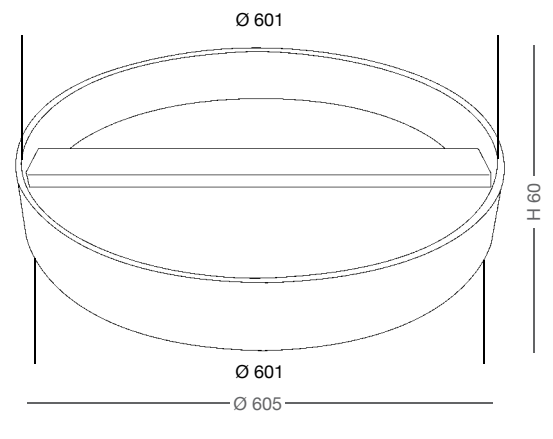

J122
Ø605 x H60

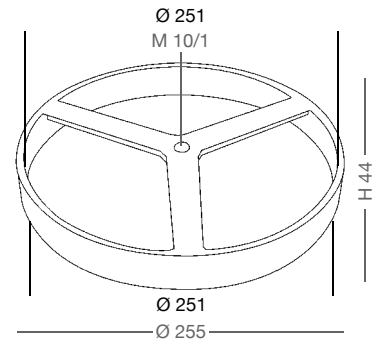

J001
Ø250 x H44

fori/holes
-05, -06, -08, -10, -12

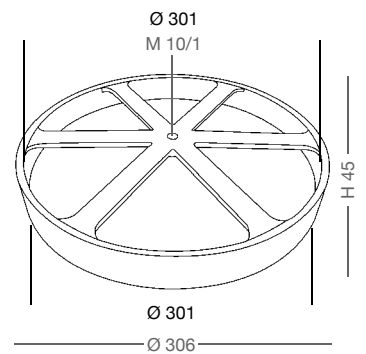

J107
Ø300 x H45

fori/holes
-06, -08, -10, -12

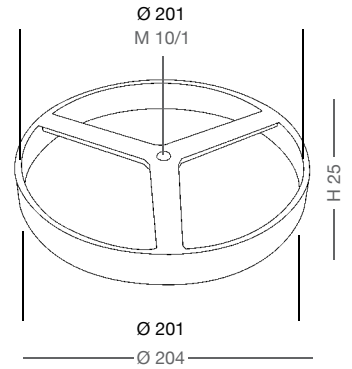

20-001
Ø200 x H25

fori/holes
-03, -04, -05, -06, -08, -10, -12

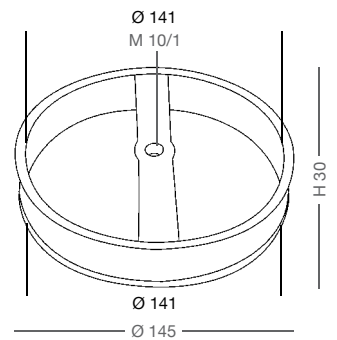

J085
Ø145 x H30

fori/holes
-05, -06

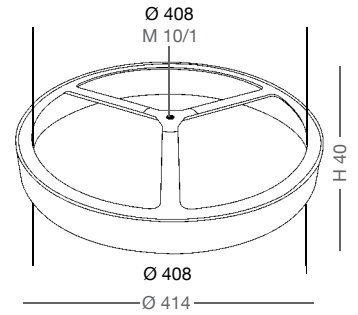

20-013
 $\text{Ø}414 \times H40$

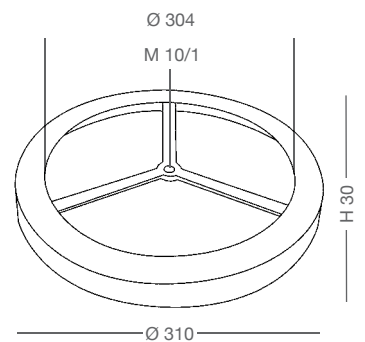

J113
 $\text{Ø}310 \times H30$

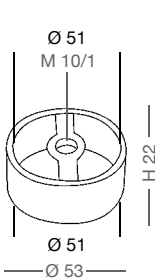

20-011
Ø50 x H22

fori/holes
-01, -02, -03, -04, -05,
-06

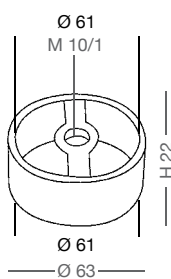

20-010
Ø60 x H22

fori/holes
-01, -02, -03, -04, -05,
-06, -30, -31, -32, -33

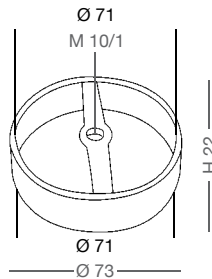

20-009
Ø70 x H22

fori/holes
-01, -02, -03, -04, -05,
-06, -08

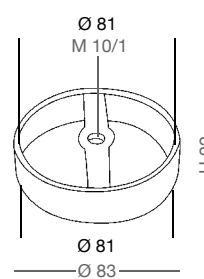

20-008
Ø80 x H22

fori/holes
-01, -02, -03, -04, -05,
-06, -08, -30

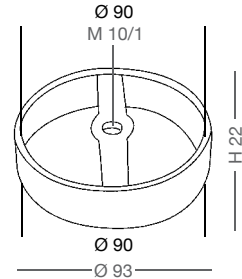

20-007
Ø90 x H22

fori/holes
-02, -03, -04, -05, -06,
-08, -10

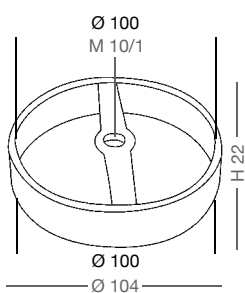

20-006
Ø100 x H22

fori/holes
-02, -03, -04, -05, -06,
-08, -10, -12, -30

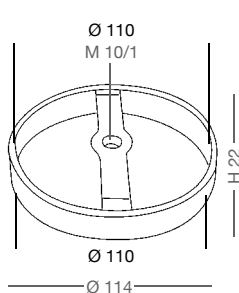

20-005
Ø110 x H22

fori/holes
-02, -03, -04, -05, -06,
-08, -10, -12

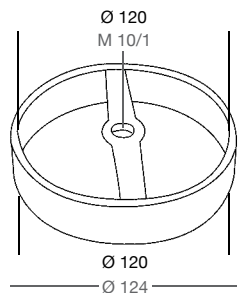

20-004
Ø120 x H22

fori/holes
-03, -04, -05, -06, -08,
-10, -12, -30, -36

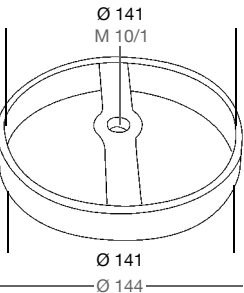

20-003
Ø140 x H24

fori/holes
-03, -04, -05, -06, -08,
-10, -12

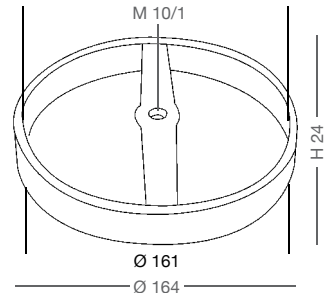

20-002
Ø160 x H24

fori/holes
-03, -04, -05, -06, -08,
-10, -12

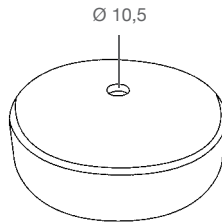

J029 Ø45 x H23 **J072** Ø55 x H25 **J032** Ø70 x H23 **J034** Ø90 x H23

J030 Ø50 x H23 **J031** Ø60 x H23 **J033** Ø80 x H23 **J035** Ø100 x H23

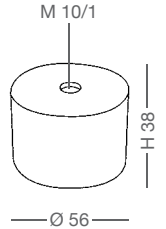

J094
Ø56 x H38

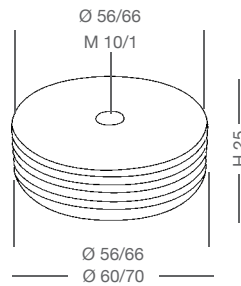

J099
Ø60 x H25

J100
Ø70 x H25

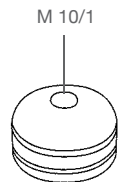

J070
Ø39 x H25

J071
Ø45 x H25

fori/holes
-02, -03

