

O



O.8



O.9

ARTICOLO ITEM	Ø D	Ø d	H
O 8	185	135	23
O 9	130	78	23
O 20	200	100	25
O 23	150	100	25



O.20



O.23

300

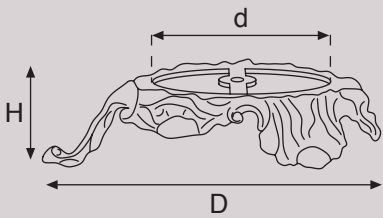

O.15



O.16



O.17

ARTICOLO ITEM	Ø	H	FILETTO THREAD
O 15	65	65	10x1
O 16	47	112	
O 17	120	58	



O.25



O.245



O.40

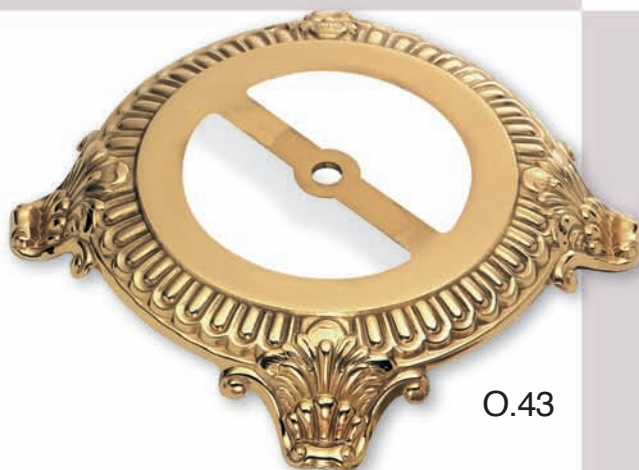

O.43



O.44

ARTICOLO ITEM	Ø D	Ø d	H	FOTO / FILETTO HOLE / THREAD
O 25	210	92	33	10,2
O 40	210	105	50	10,2
O 43	225	135	35	10,2
O 44	165	45	43	10x1
O 245	170	70	25	10,2

O



O.55

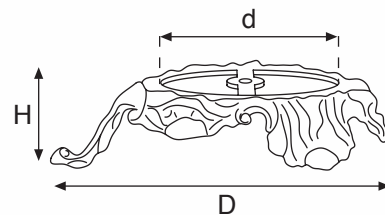

O.57

302

ARTICOLO ITEM	Ø D	Ø d	H	FORO / FILETTO HOLE / THREAD
O 55	260	115	63	10,2
O 57	320	37	80	10,2
O 152	160	-	28	10,2
O 172 (*)	185	-	56	10x1

(*) Articolo satinato / Grinded piece



O.152



O.172



O.24



O.41



O.93



O.85
O.85 GR (senza foro laterale)

ARTICOLO ITEM	Ø D	Ø d	H	FORO / FILETTO HOLE / THREAD
O 24	125	31	35	10,2
O 41	155	58x58	29	10x1
O 85	140	70	32	10,2+10,2
O 85 GR	140	70	32	10,2
O 93	106	46	26	10x1
O 193	110	-	40	10x1
O 194	145	-	56	10x1



O.193



O.194

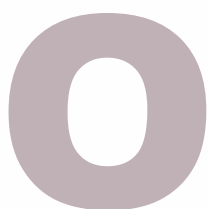

O



O.29



O.36



O.30



O.37



O.32



O.38



O.31



O.33



O.39



O.34



O.35

304

ARTICOLO ITEM		Ø	H	FILETTO THREAD
O 29	Torn.	125	32	10x1
O 30	Torn.	35	40	
O 31	Torn.	35	39	
O 32		65	24	
O 33	Torn.	40	140	
O 34	Torn.	30	38	
O 35		98	19	
O 36	Torn.	115	16	
O 37	Torn.	93	93	
O 38		105	10	
O 39	Torn.	145	36	10x1

ARTICOLO ITEM	Ø	H	FILETTO THREAD
K 23*	145	455	10x1
K 51*	120	350	10x1

* Composto da n. 11 pezzi non assemblati
Composed by n. 11 pieces not assembled



O.255



O.254



O.253



O.252



O.241



O.251



O.242



O.250



O.244



O.243



O.195

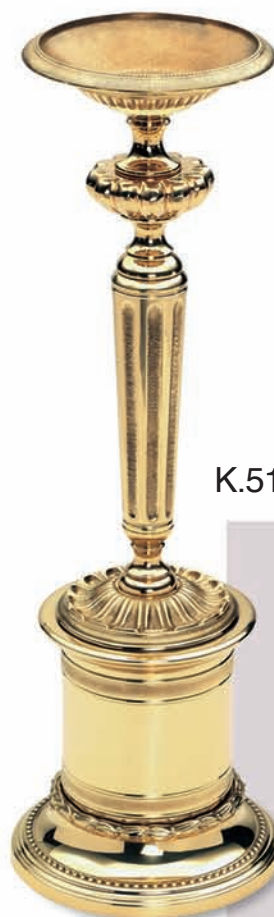

K.51



K.23

ARTICOLO ITEM		Ø	H	FILETTO THREAD
O 195	Torn.	120	34	10x1
O 241	Torn.	95/75	14	
O 242	Torn.	77/75	75	
O 243		87/75	10	
O 244		80	16	
O 250	Torn.	26	30	
O 251	Torn.	32	110	
O 252	Torn.	27	31	
O 253		50	25	Imp. 22,5
O 254	Torn.	30	32	
O 255	Torn.	102	25	10x1

O



O.59



O.62



O.61

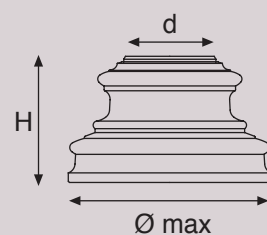

O.91



O.63



O.92



O.166

306

ARTICOLO ITEM		Ø MAX	Ø d	H	FORO / FILETTO HOLE / THREAD
O 59	Torn.	160	55	63	10,2
O 61	Torn.	145	55	107	10,2
O 62	Torn.	160	55	125	10,2
O 63	Torn.	95	-	26	10x1
O 91	Torn.	155	43	106	10,2
O 92	Torn.	175	80	110	10,2
O 166	Torn.	160	104	33	10,2

ARTICOLI TORNITI



O.47

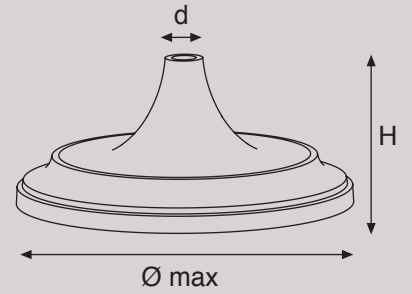

O.65 - O.148 - O.149

ARTICOLO ITEM		Ø MAX	Ø d	H	FORO / FILETTO HOLE / THREAD
O 47	Torn.	285	49	110	Ø 9
O 65	Torn.	295	33	125	13x1
O 148	Torn.	140	20	66	10x1
O 149	Torn.	200	26	87	10x1
O 227 (*)	Torn.	140	120	20	10x1
O 228 (*)	Torn.	140	20	44	10x1

(*) Not available for U.S.A. market



O.148



O.149



O.65



O.227



O.228

O

O.64



O.94



O.171



O.199
(Fil 10x1)



O.200



ARTICOLO ITEM	Ø	H	FORO /FILETTO HOLE / THREAD
O 64	195	43	n.1 10x1
O 94	162	50	n.1 10x1
O 171 (*)	200	42	10x1
O 199	100	16	10x1 cieco
O 200	163	30	10,2

* Articolo Satinato / Grinded pieces



O.89



O.90

ARTICOLO ITEM	Ø MAX	Ø TOP	H
O 89	130	100	28
O 90	160	120	32
O 117	205	140	25



O.117



O.83 SM

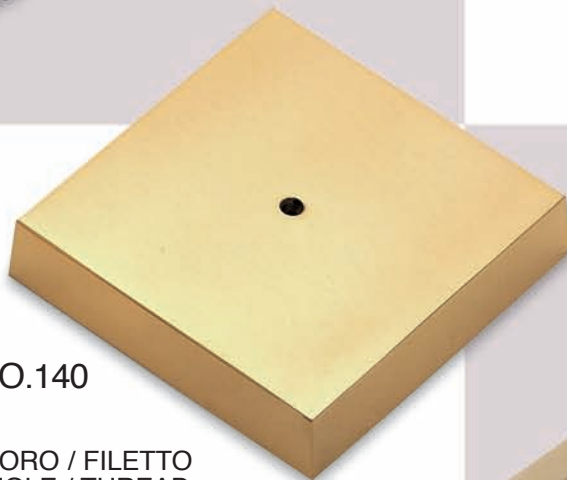

O.140



O.142

ARTICOLO ITEM	MISURE DIMENSIONS	FORO / FILETTO HOLE / THREAD
O 83 SM	160X160X34	10,2
O 140	160X160X35	10X1
O 141	130X130X35	-
O 142	160X120X35	-
R 67	135X135X31	-



O.141

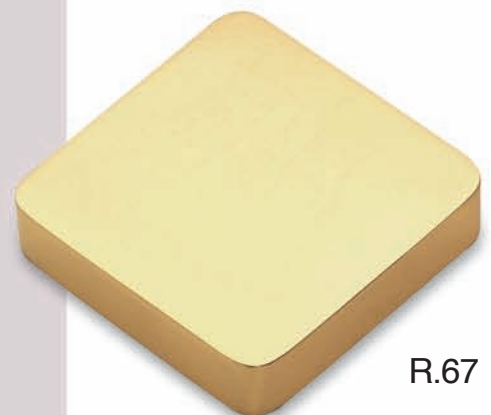

R.67



O



O.73
O.73 FOR



O.75

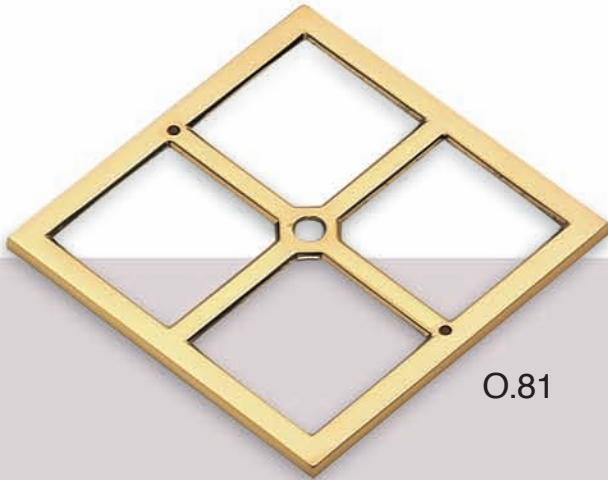

O.81

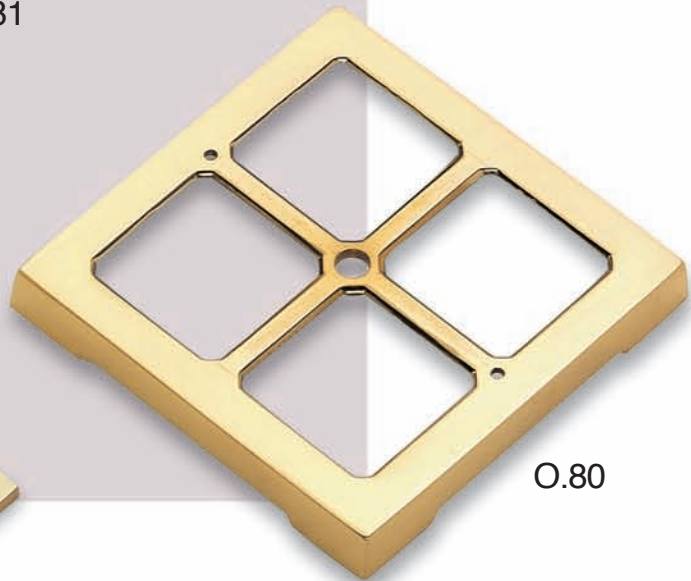

O.80

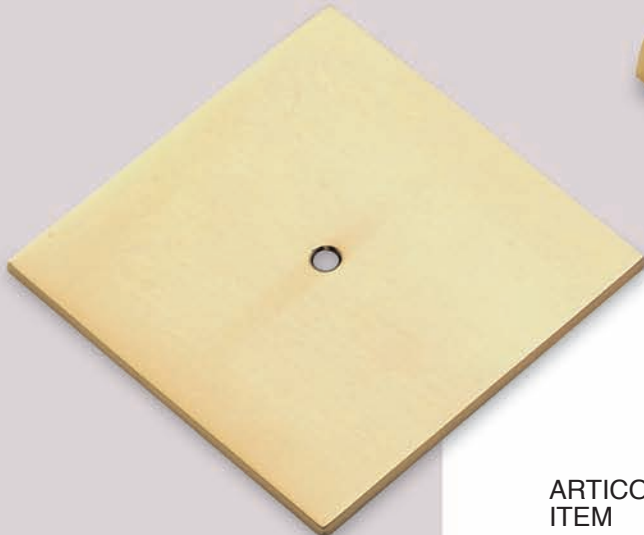

O.77

310

ARTICOLO ITEM	MISURE DIMENSIONS	SUPERIORE TOP	FORI / FILETTI HOLES / THREADS
O 73	130x130x21	125x125	n.1 10x1 + n.2 M4
O 73 FOR (*)	130x130x21	125x125	n.1 10x1 + n.2 M4
O 75	150x150x21	145x145	n.1 10x1
O 77	135x135x5	135x135	n.1 10x1 + n.2 M4
O 80	150x150x20	145x145	n.3 fori / holes
O 81	135x135x5	135x135	n.3 fori / holes

(*) con foro laterale / with side hole

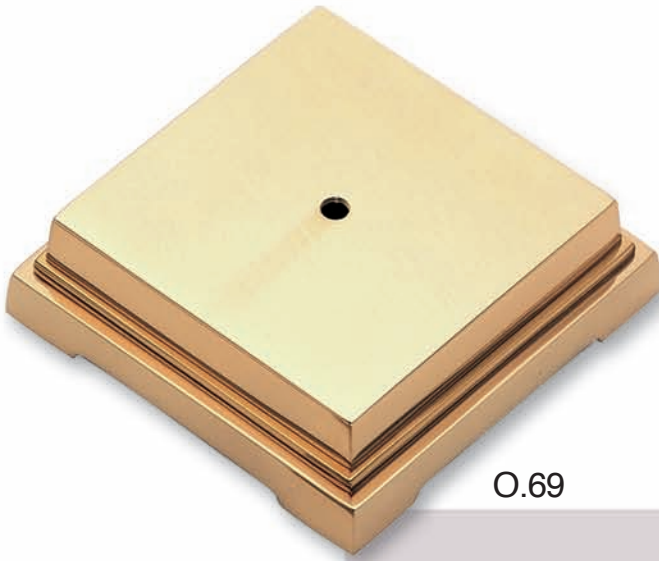

O.69

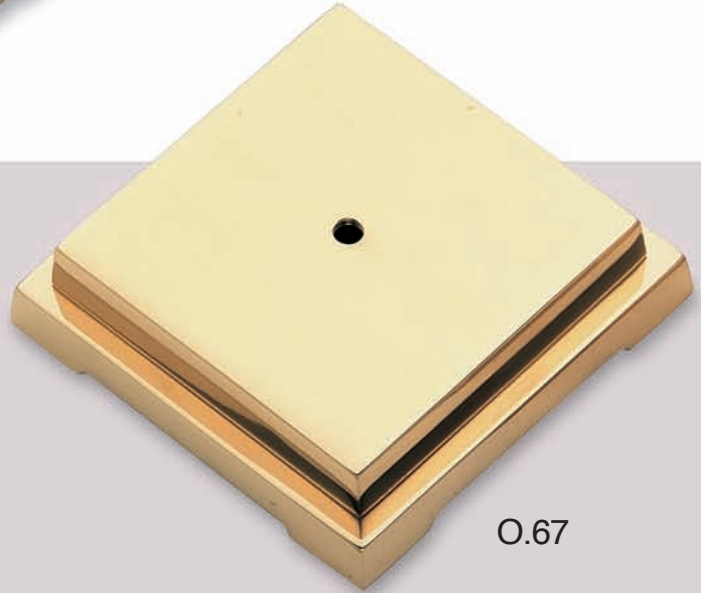

O.67

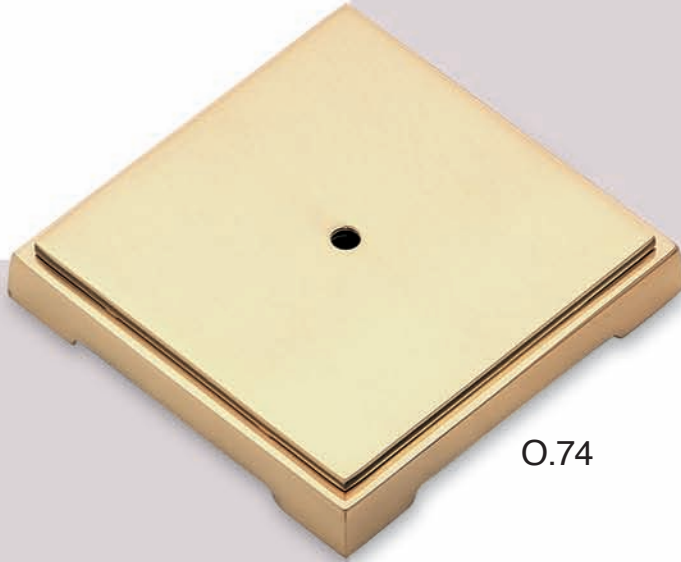

O.74

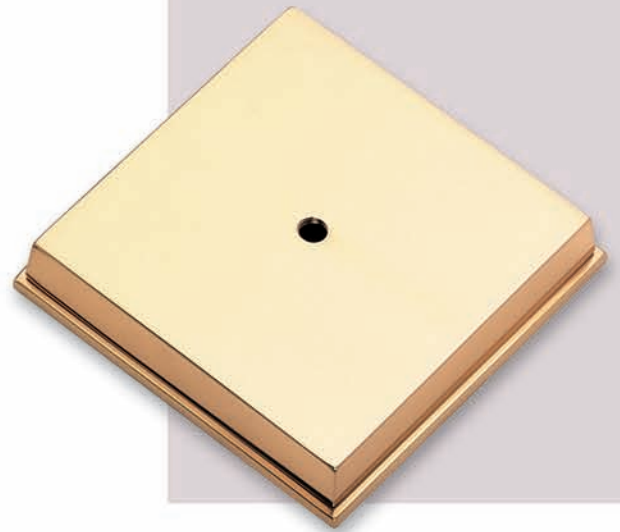

O.71

ARTICOLO ITEM	MISURE DIMENSIONS	SUPERIORE TOP	COMPONENTI COMPONENTS
O 67	150x150x43	125x125	O.80 + O.73
O 69	150x150x47	125x125	O.80 + O.81 + O.73
O 71	135x135x26	125x125	O.81 + O.73
O 74	150x150x26	135x135	O.80 + O.77

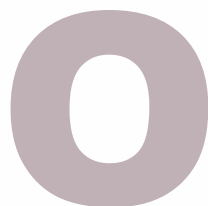

O

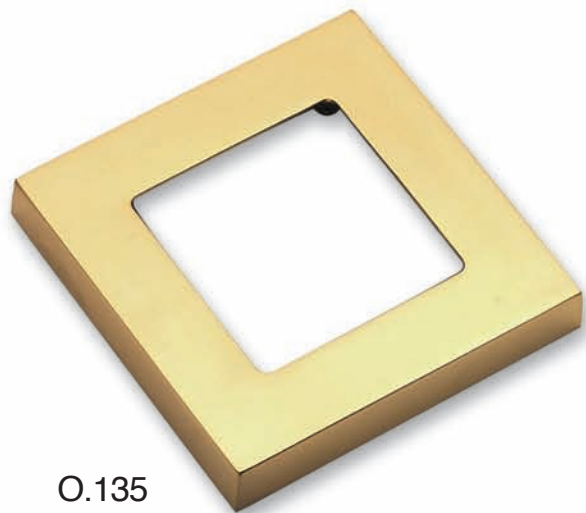

O.135

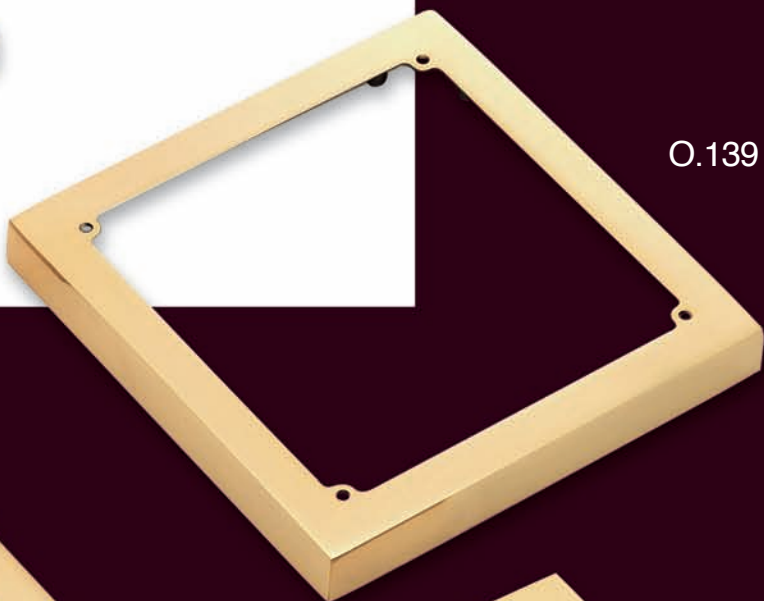

O.139

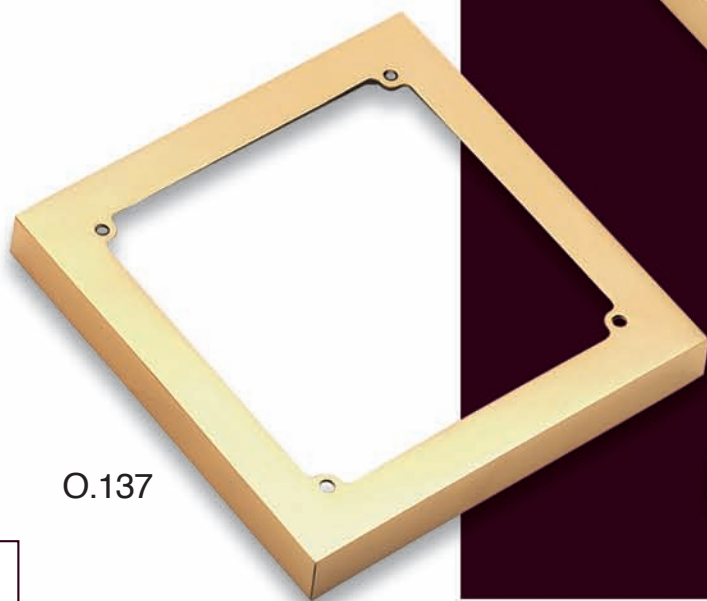

O.137



O.138



O.136

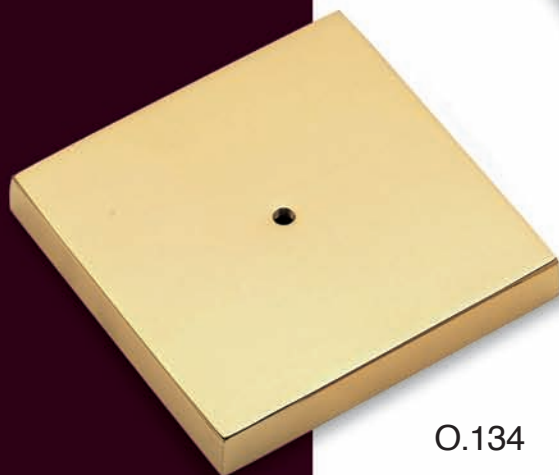

O.134

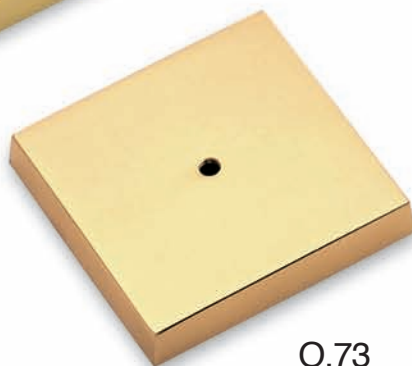

O.73

312

ARTICOLO
ITEM

MISURE
DIMENSIONS

FILETTI
THREADS

O 73	130X130X21	n.1 10x1 + n.2 M4
O 134	175X175X25	n.1 10x1 + n.4 M6
O 135	175X175X25	n.4 M6
O 136	215X215X28	n.1 10x1 + n.4 M6
O 137	215X215X28	n.4 M6 + n.4 fori 6,5
O 138	255X255X31	n.1 10x1 + n.4 M6
O 139	255X255X31	n.4 M6 + n.4 fori 6,5

Articoli disponibili anche smerigliati (SM) o lucidati
Available also in grinded (GR) or polished finish

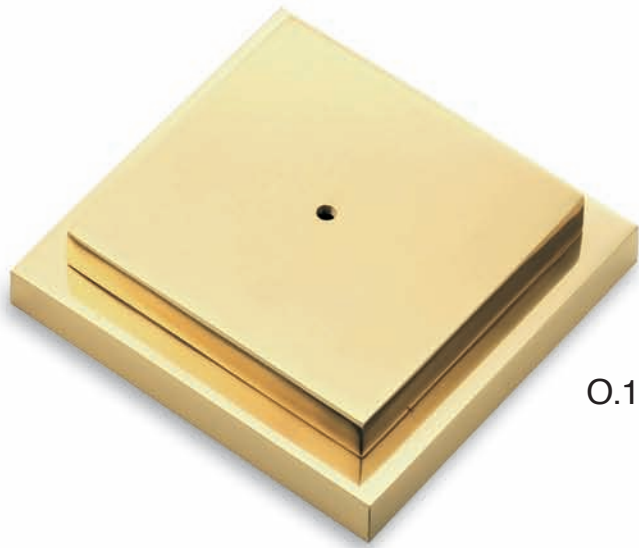

O.144

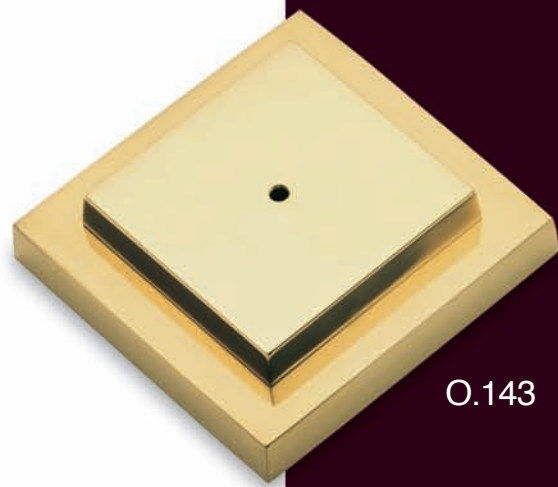

O.143



O.146

ARTICOLO ITEM	MISURE DIMENSIONS	SUP TOP	COMPONENTI COMPONENTS
O 143	175x175x46	125x125	O.73 + O.135
O 144	215x215x53	172x172	O.134 + O.137
O 145	255x255x59	212x212	O.136 + O.139
O 146	255x255x84	172x172	O.134 + O.137 + O.139
Z 202	35x45x31		n.2 fori 6,5

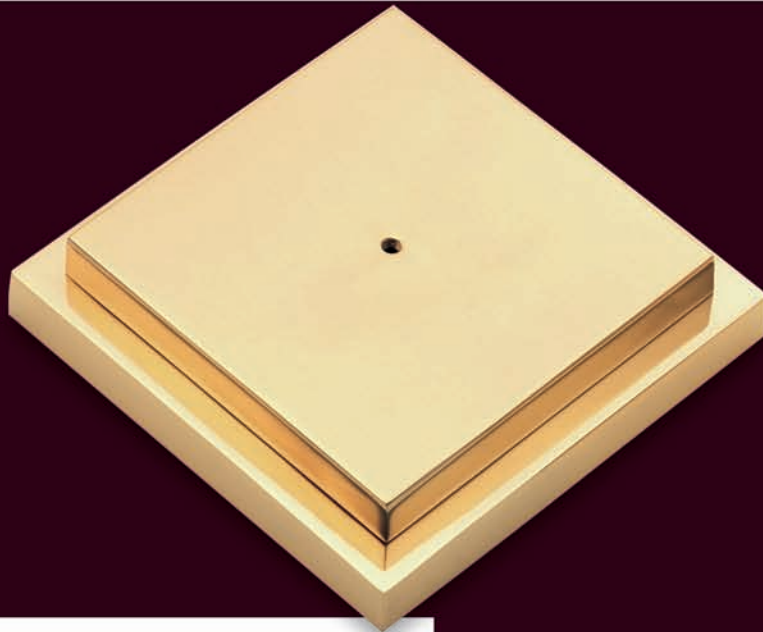

O.145



Z.202



O.145 fil.
+ n.4 Z.202

O

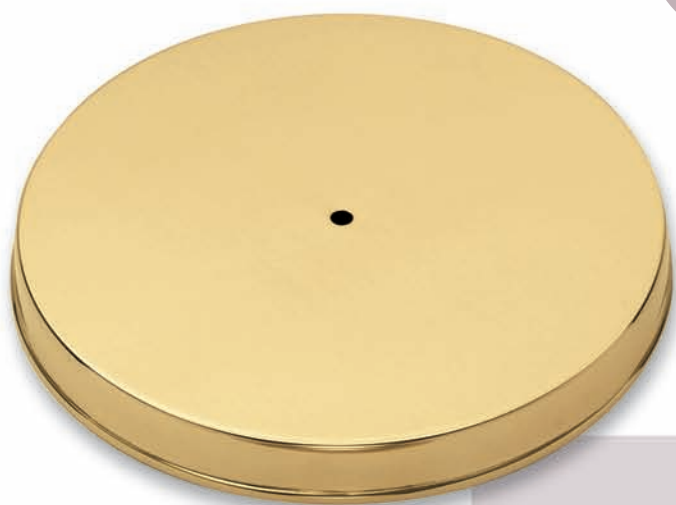

O.82
O.82 SM



O.147

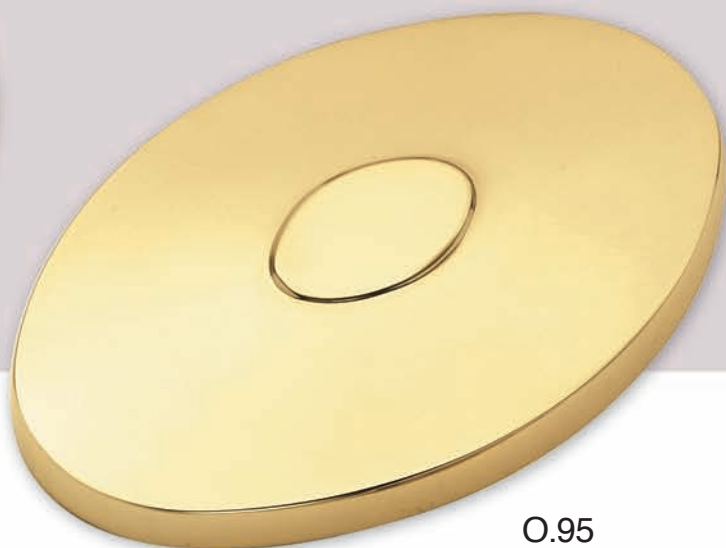

O.95

314

ARTICOLO ITEM	MISURE DIMENSIONS	H	FORO HOLE	LAVORAZIONI
O 82	Ø 265	31	9	grezzo / raw
O 82 SM	Ø 265	31	9	smerigliato fine
O 95	310x210	36	-	grezzo
O 147	240x145	34	-	grezzo
O 173	Ø 240	54	10x1	grezzo / raw
O 173 SM	Ø 240	54	10x1	smerigliato fine



O.173
O.173 SM



O.98



O.99

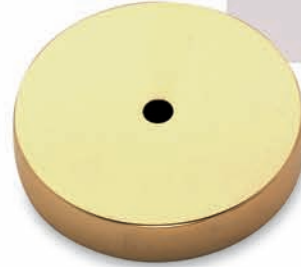

O.100

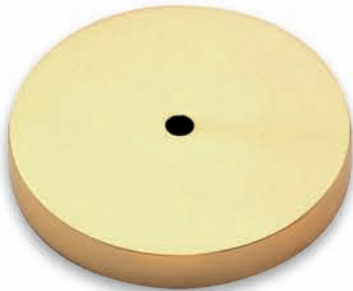

O.102

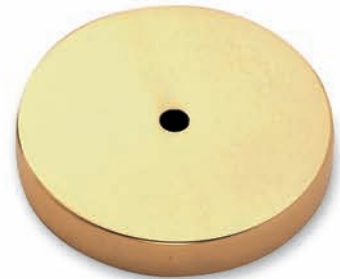

O.101

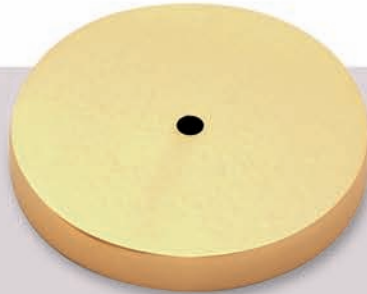

O.103

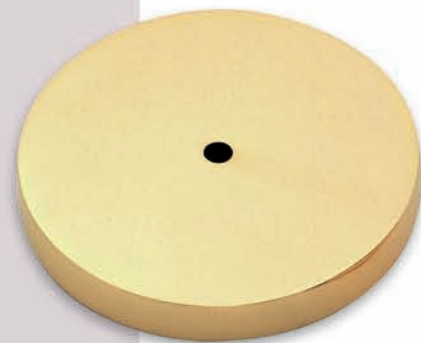

O.104

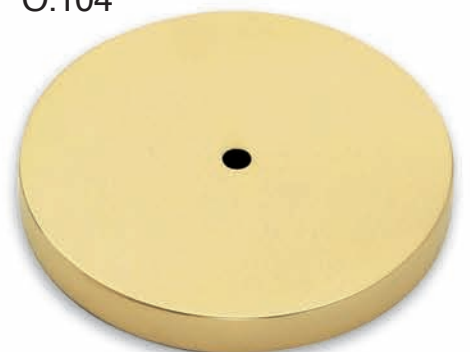

O.105

ARTICOLO ITEM	Ø	H
O 98	76	19
O 99	89	19
O 100	102	19
O 101	115	19
O 102	128	19
O 103	139	19
O 104	147	19
O 105	160	19



O

ARTICOLO ITEM	MISURE DIMENSIONS	Ø SUP Ø TOP
------------------	----------------------	----------------

O 106	132x132x36	90
-------	------------	----

O 107	160x160x40	110
-------	------------	-----

O 108	218x218x53	150
-------	------------	-----

O 110	110x110x20	87x87
-------	------------	-------

O 111	160x160x25	128x128
-------	------------	---------

O 207	105x105x30	70
-------	------------	----

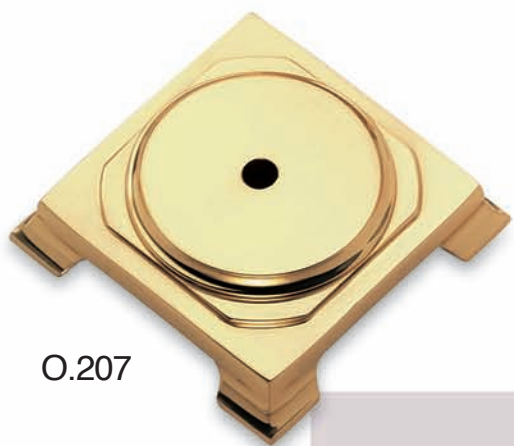

O.207

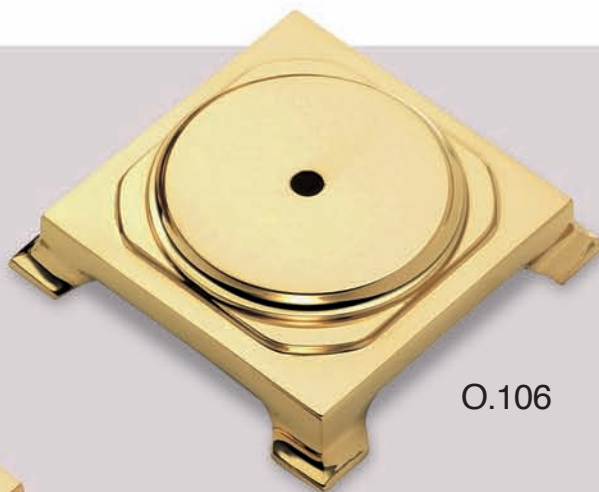

O.106

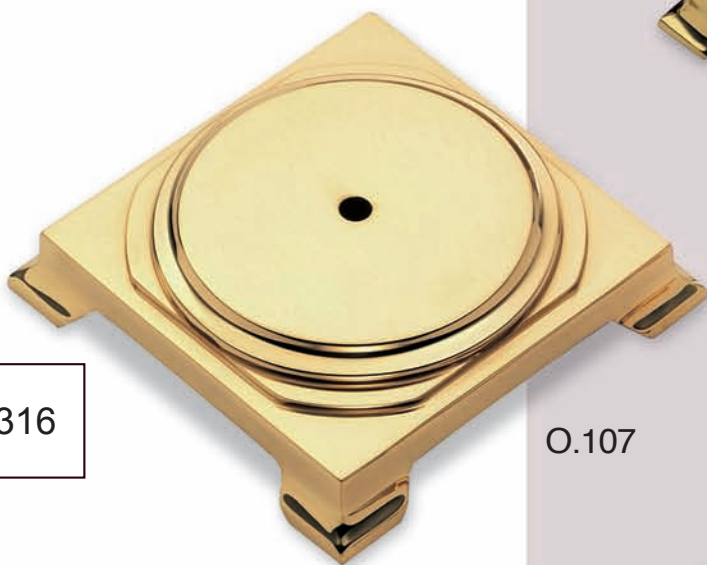

O.107

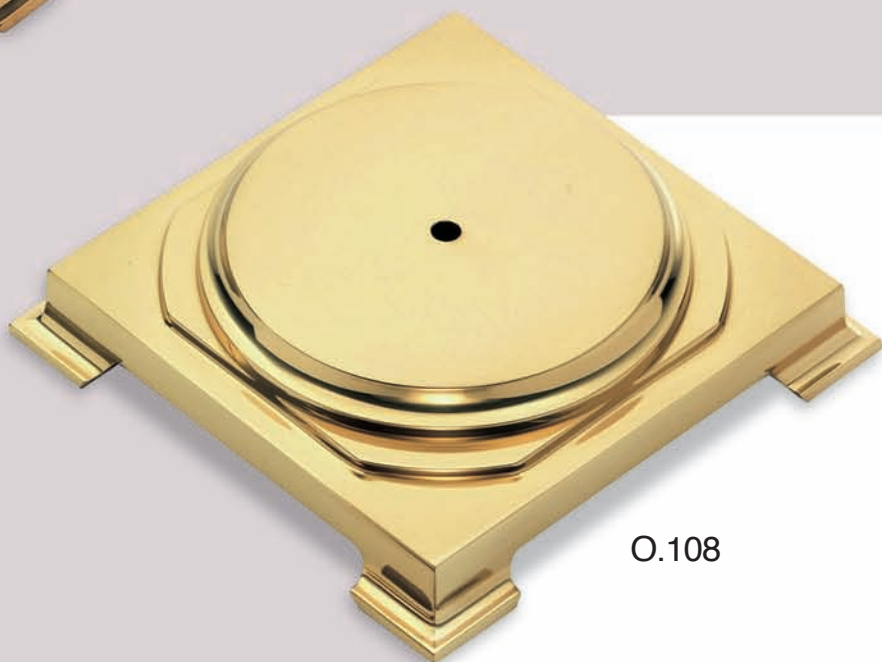

O.108

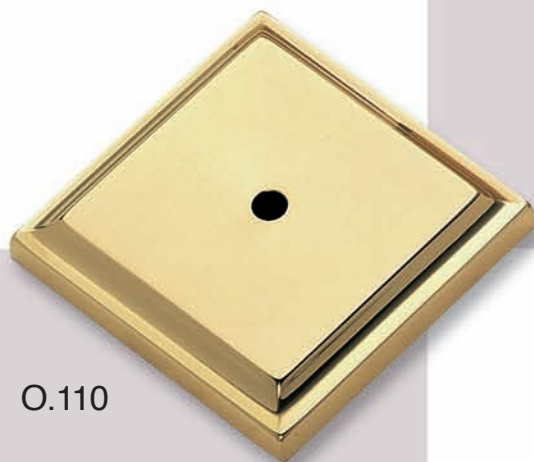

O.110



O.111

316

ARTICOLO ITEM	MISURE DIMENSIONS	Ø SUP Ø TOP	Ø IMPOSTA INTERNA Ø INSIDE COUNTERSINK
O 150	Ø130x21	115	120
O 151	Ø160x26	145	150
O 156	90x90x20	70	-
O 157	112x112x27	89	-
O 158	130x130x32	105	-



O.150

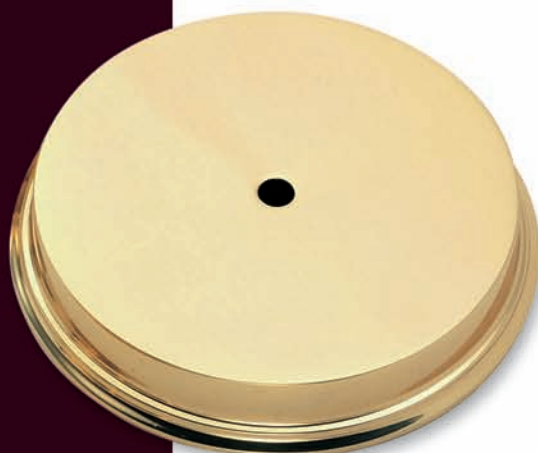

O.151

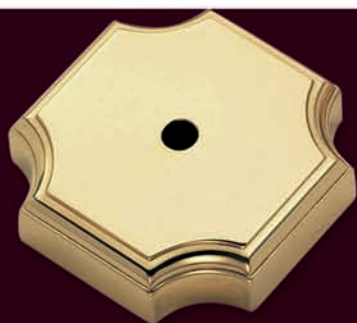

O.156

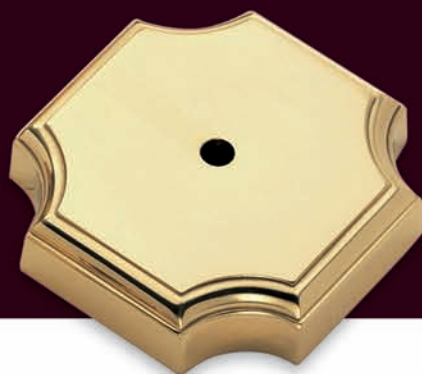

O.157

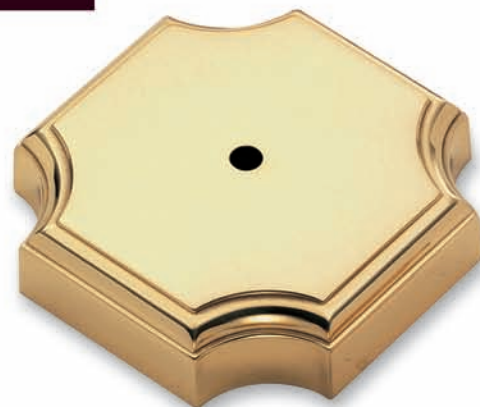

O.158

O

O

O.155

O.154

O.153

O.160

O.204

O.170

O.165

318

ARTICOLO ITEM	MISURE DIMENSIONS	Ø SUP Ø TOP	FORO / FILETTO HOLE / THREAD
O 153	41x41x20	25x25	-
O 154	53x53x23	30x30	-
O 155	71x71x24	49x49	-
O 160	140x140x56	70x70	10,2
O 165	100x100x14	100x100	10x1
O 170	100x100x27	70x70	10x1
O 204	110x110x45	55x55	10,2



O.211

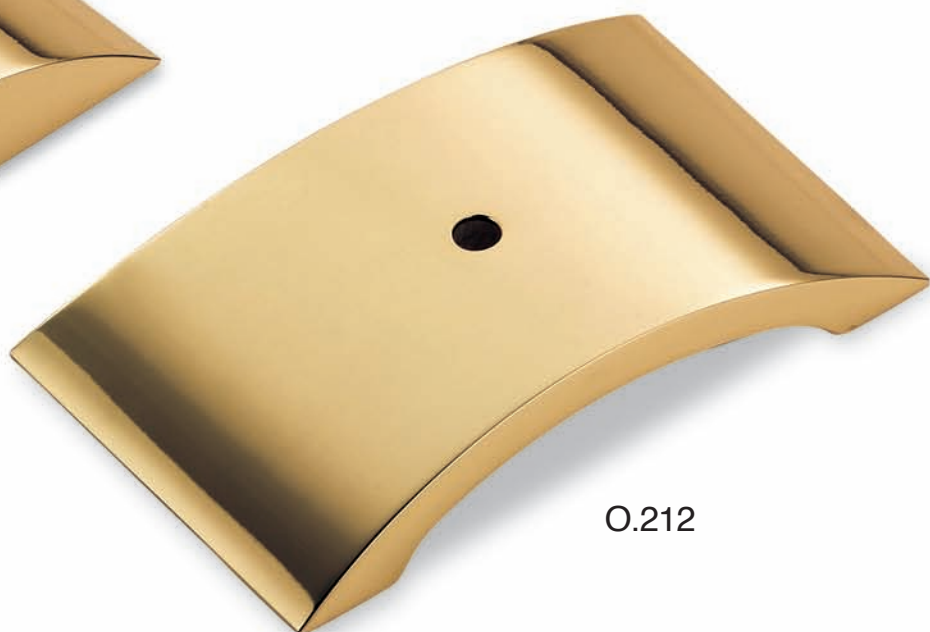

O.212

ARTICOLO ITEM	MISURE DIMENSIONS	Ø SUP Ø TOP
O 211	140x82x24	-
O 212	175x113x26	-
O 213	Ø75x30	-
O 214	75x75x30	-
O 218	105x105x25	60x60



O.213



O.214

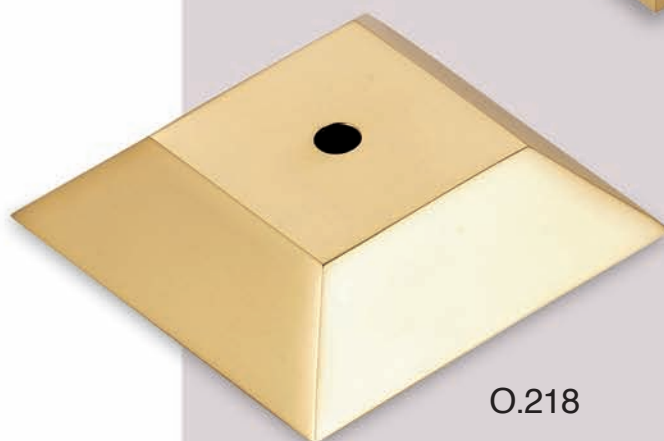

O.218

O

O

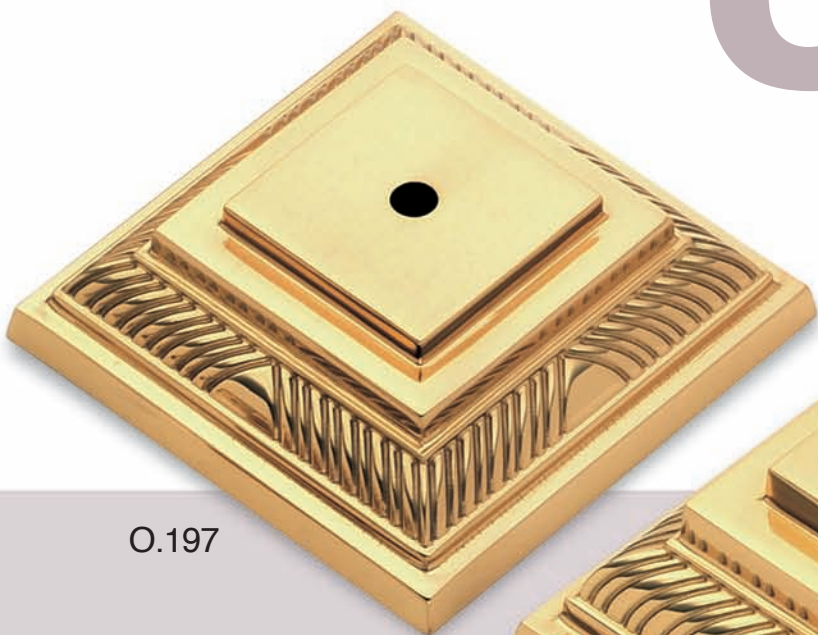

O.197

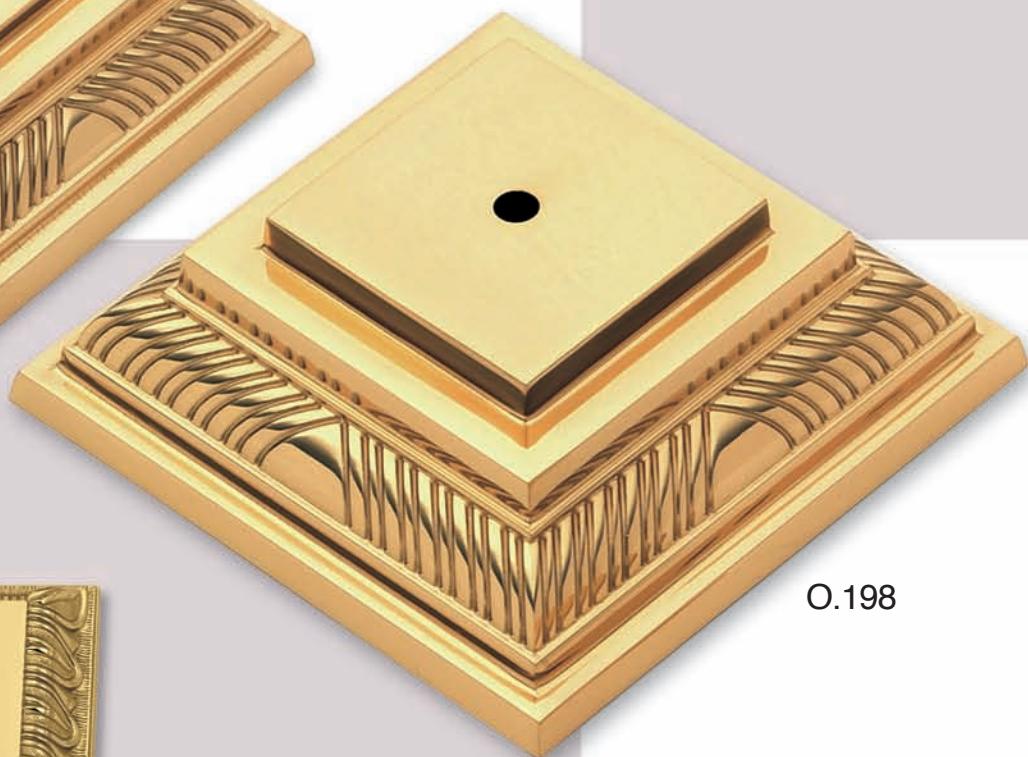

O.198

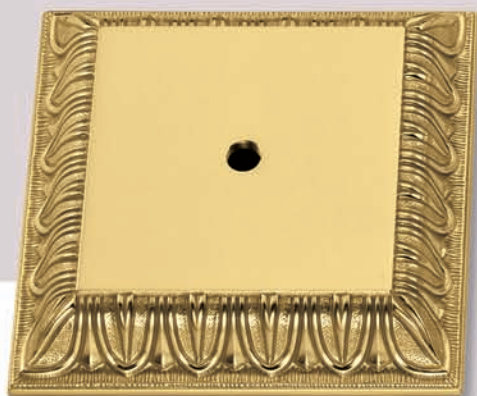

O.231

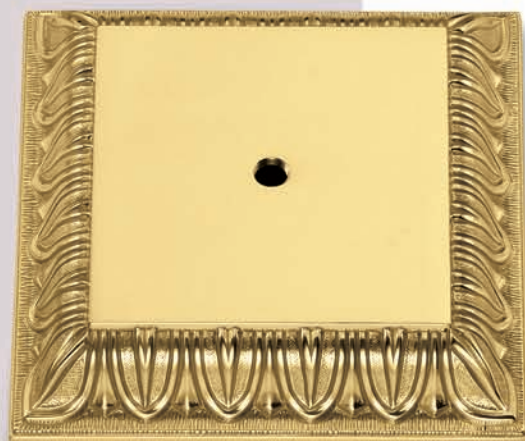

O.232



O.233

320

ARTICOLO ITEM	MISURE DIMENSIONS	SUP TOP	FORO / FILETTO HOLE / THREAD
O 197	130x130x42	60x60	10,2
O 198	170x170x58	81x81	10,2
O 231	120x120x23	83x83	10x1
O 232	140x140x27	97x97	10x1
O 233	155x155x50	97x97	10x1



O.235

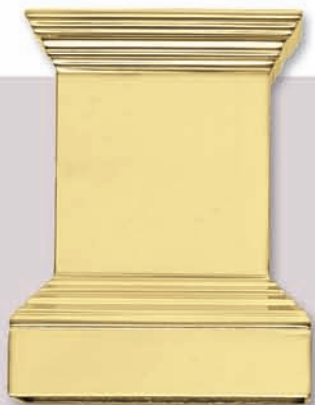

O.234

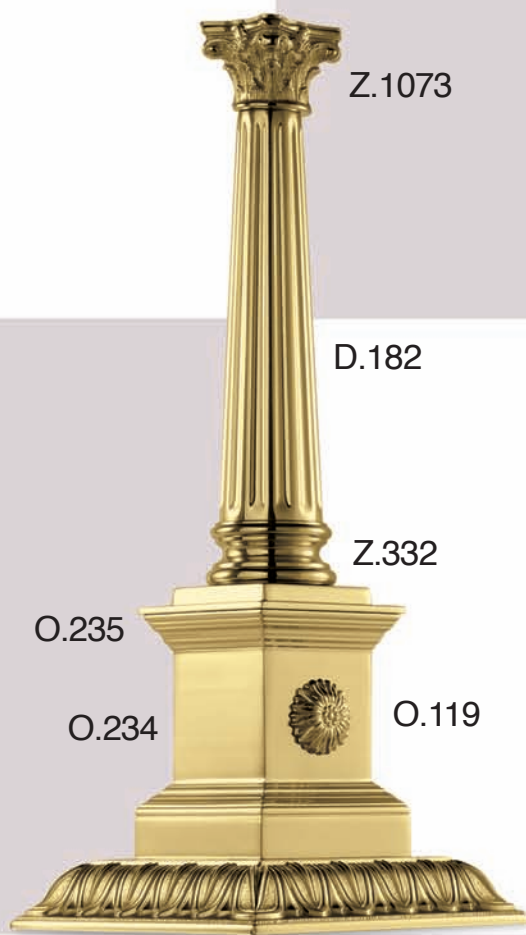

Z.1073

D.182

Z.332

O.235

O.234

O.119

O.232

ARTICOLO ITEM	MISURE DIMENSIONS	SUP TOP	FORO / FILETTO HOLE / THREAD
O 234	75x75x95	70x70	-
O 235	72x72x11	52x52	10,2
O 248 SM	80x80x20	117x117	10x1
O 249 SM	110x110x20	137x137	10x1

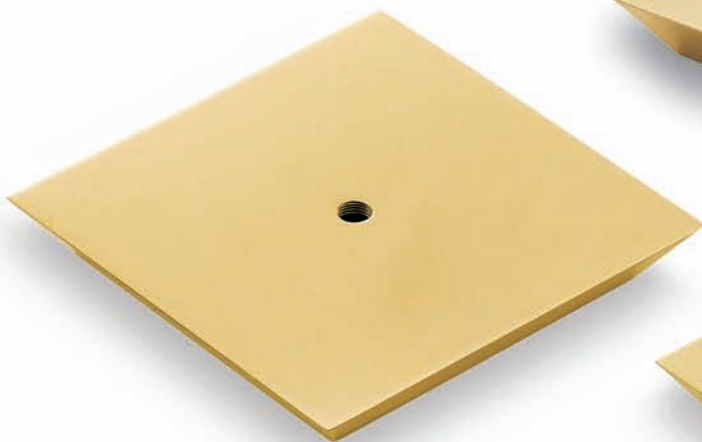

O.249

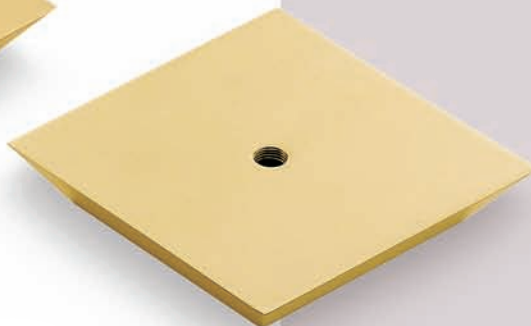

O.248

O



O.39



O.195

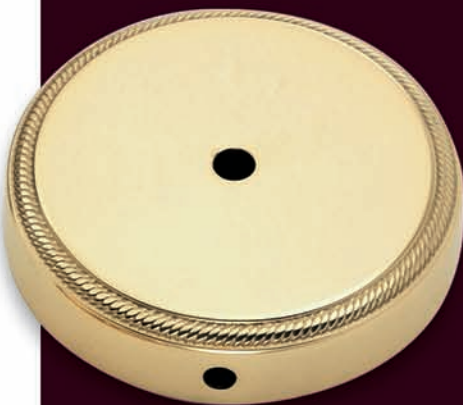
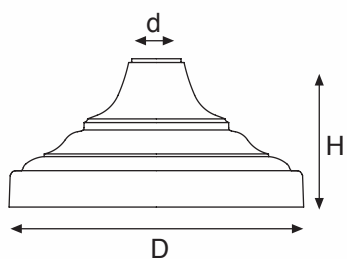

O.161

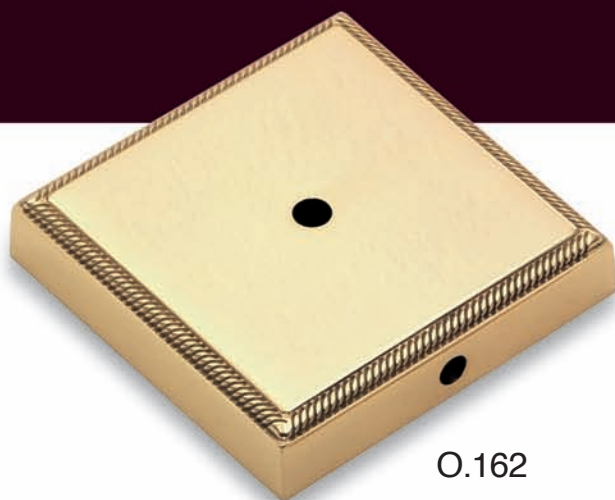

O.162



O.187



O.188

322

ARTICOLO ITEM	MISURE DIMENSIONS	d SUP d TOP	FORO / FILETTO HOLE / THREAD
O 39 Torn	Ø145x35	Ø92	n.1 10x1
O 161	Ø120x24	Ø103	10,2
O 162	120x120x24	103x103	10,2
O 187 Torn	Ø125x63	25	10,2
O 188 Torn	Ø160x80	30	10x1
O 195 Torn	Ø120x30	75	10x1



O.206



O.205



O.220



O.219

ARTICOLO ITEM	MISURE DIMENSIONS	SUP TOP	FORO / FILETTO HOLE / THREAD
O 205	Ø140xh20	Ø56	-
O 206	Ø200xh25	Ø82	-
O 219	Ø110xh35	Ø41	10x1
O 220	Ø140xh45	Ø51	10x1
O 222	175x80x22	155x63	
O 223	260x120x25	235x95	



O.222

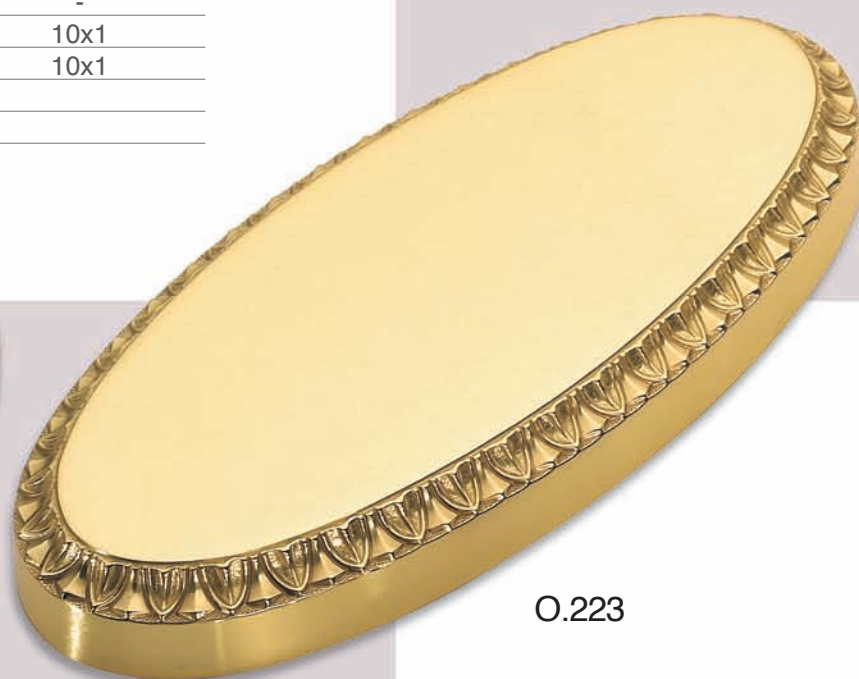

O.223



O



O.168



O.169



O.174

324

ARTICOLO ITEM	Ø MAX	Ø INF Ø BOTTOM	H	Ø SUP Ø TOP	FILETTO THREAD
O 168 Torn	215	130	50	30	10x1
O 169 Torn	215	130	50	30	10x1
O 174 Torn	220	130	50	30	10x1



O.237



O.238



O.239



O.240

ARTICOLO ITEM	Ø MAX	Ø SUP Ø TOP	H
O 237	160	84	35
O 238	225	116	50
O 239	162	86	46
O 240	225	121	64

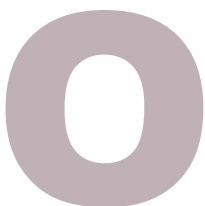

O

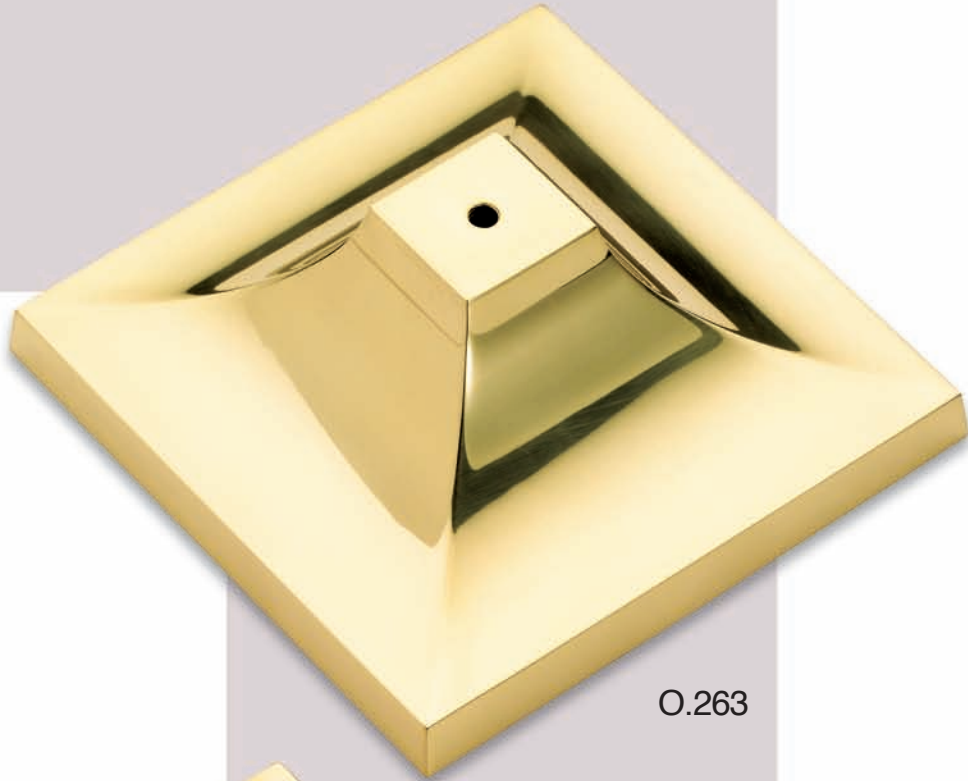

O.263

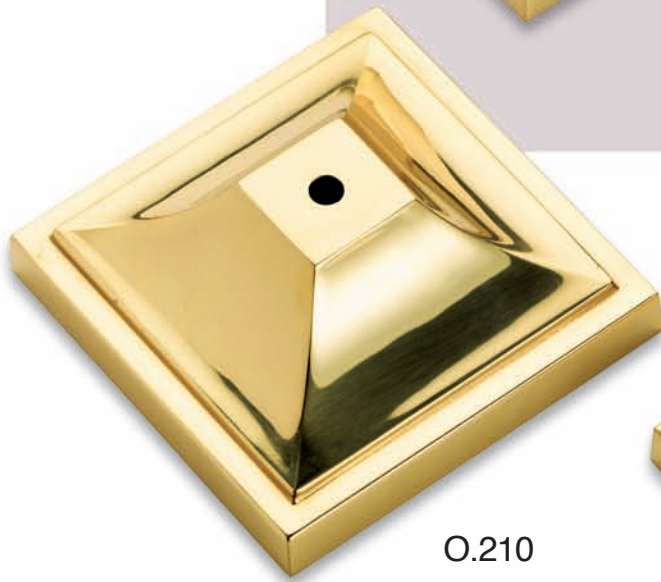

O.210



O.209
O.209 FOR



O.208
O.208 FOR

326

ARTICOLO ITEM	H	LATO SIDE
O 208	38	83
O 208 FOR*	38	83
O 209	50	110
O 209 FOR*	50	110
O 210	57	140
O 263	82	220

* Con 2 fori laterali + staffa fil. M4
With bracket and two side holes

O.258



O.258-25



ARTICOLO ITEM		Ø	Ø SUP	H	FILETTO THREAD
O 258	Torn	307	20	190	10x1
O 258-25	Torn	307	25	190	10x1

Vedi anche a pag. 56

See also on page 56



O

ARTICOLO ITEM	MISURE DIMENSIONS	FILETTI THREADS
O 216 (*)	150x100	n.4 M4
O 217 (*)	100x100	n.4 M4

(*) Fornito con 4 sfere Z.256 Ø12
Supplied with 4 spheres Z.256 Ø12



O.216



O.217



4015



4014

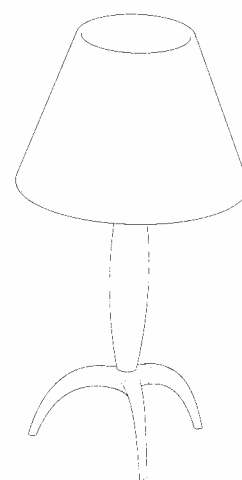

328

ARTICOLO ITEM	Ø MAX	H	FILETTO THREAD
L 88 pass	80	14	10x1
L 89 pass	110	18	10x1
O 229	150	60	10x1
O 230	190	75	10x1
4014 Vetro	150		
4015 Vetro	200		



O.229

L.88 pass



O.230

L.89 pass

ARTICOLO ITEM	Ø / L	H	FORO/FILETTO HOLE/THREAD
F 23 - 3	60	26	n.3 fori / holes
O 45	240	225	10x1



F.23-3



O.45

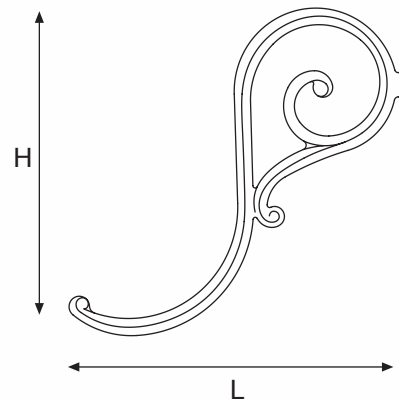

n°3 O.45 + n°1 F.23-3
Ø 520 h. 235 mm

O



O.121 M5



O.131 M5



O.132
O.132 M5



O.132 + O.123

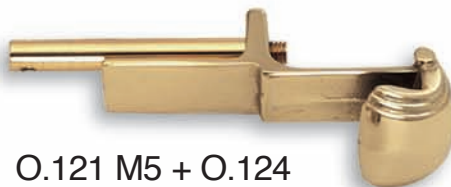

O.121 M5 + O.124



O.123



O.124



O.97



O.109

ARTICOLO ITEM	MISURE DIMENSIONS	FORO/FILETTO HOLE/THREAD
O 121 M5	65x26x32	M5
O 123	44x5	M4
O 124	52x6	M5
O 131 M5	65x34x32	M5
O 132	65x34x32	M4
O 132 M5	65x34x32	M5

330



O.49 B



O.49 B pass



O.257



O.256



O.118



O.190



O.119
O.119 M4



O.120
O.120 M4



O.203



O.175

ARTICOLO ITEM	Ø MAX	H	FORO/FILETTO HOLE/THREAD
O 49B	46	20	10x1 cieco
O 49B PASS	46	20	10,2
O 97	50	13	10x1 cieco
O 109	70	12	10x1 cieco
O 118	50	14	10x1 cieco
O 119	30	7	10x1 cieco
O 119 M4	30	7	M4
O 120	42	10	10x1 cieco
O 120 M4	42	10	M4
O 175	70	15	10x1 cieco
O 190	19	5	-
O 203	59	12	10x1 cieco
O 256	30x30	12	10x1 cieco
O 257	40x40	12	10x1 cieco



O.78



O.86

ARTICOLO ITEM	D1	D2	D3	H	FORI /FILETTI HOLES/THREADS
O 78	330	263	253	45	n.3 M4
O 86	300	215	205	45	n.3 M4
4005	300		vetro/glass		240
4011	240		vetro/glass		190

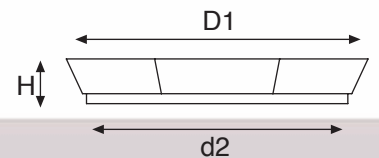
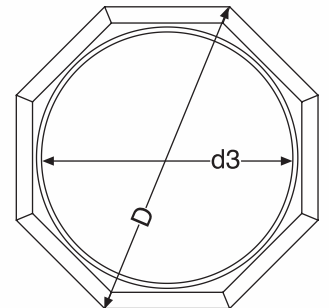

4005



4011



O



O.46



O.28



O.50



O.49

332

ARTICOLO ITEM	D1	D2	D3	H
O 28	310	205	189	30
O 46	275	185	140	27
O 49	315	190	180	54
O 50	260	152	139	50

ARTICOLO ITEM	D1	D2	D3	H
O 53	315	190	175	45
O 54	410	240	225	45
O 236	307	137	134	81



O.53



O.54



O.236

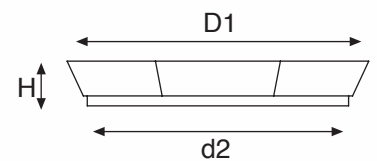
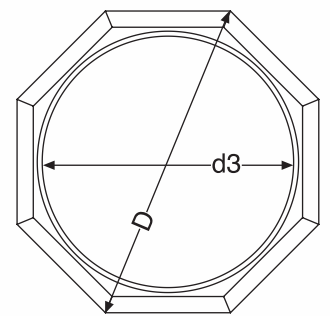

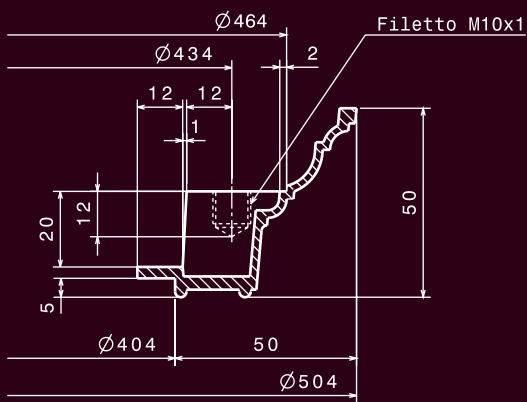

O.225

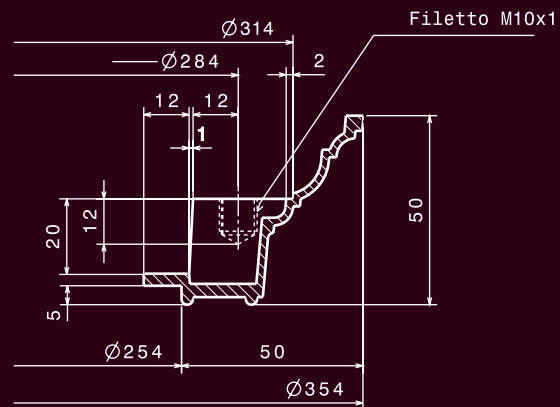

O.221



O.225



O.221

ARTICOLO ITEM	Ø MAX	Ø INT	H	FILETTO THREAD
(•) O 221	354	254	50	n.6 10x1
(•) O 225	504	404	50	n.6 10x1
(•) Not available for USA market				



O.224



O.226

ARTICOLO ITEM	Ø MAX	H	FORO CENTRALE CENTER HOLE
O 224	507	26	135
O 226	550	8	136

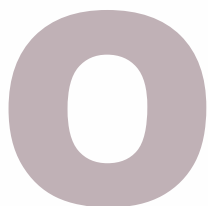

O

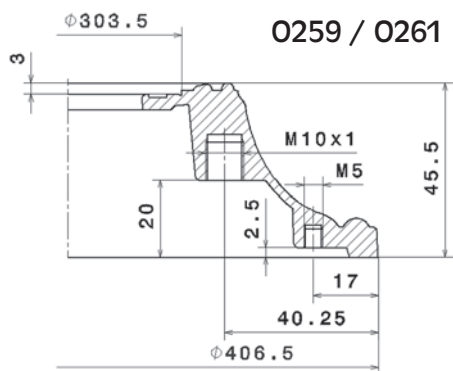

O.259 / O.261



O.259

336

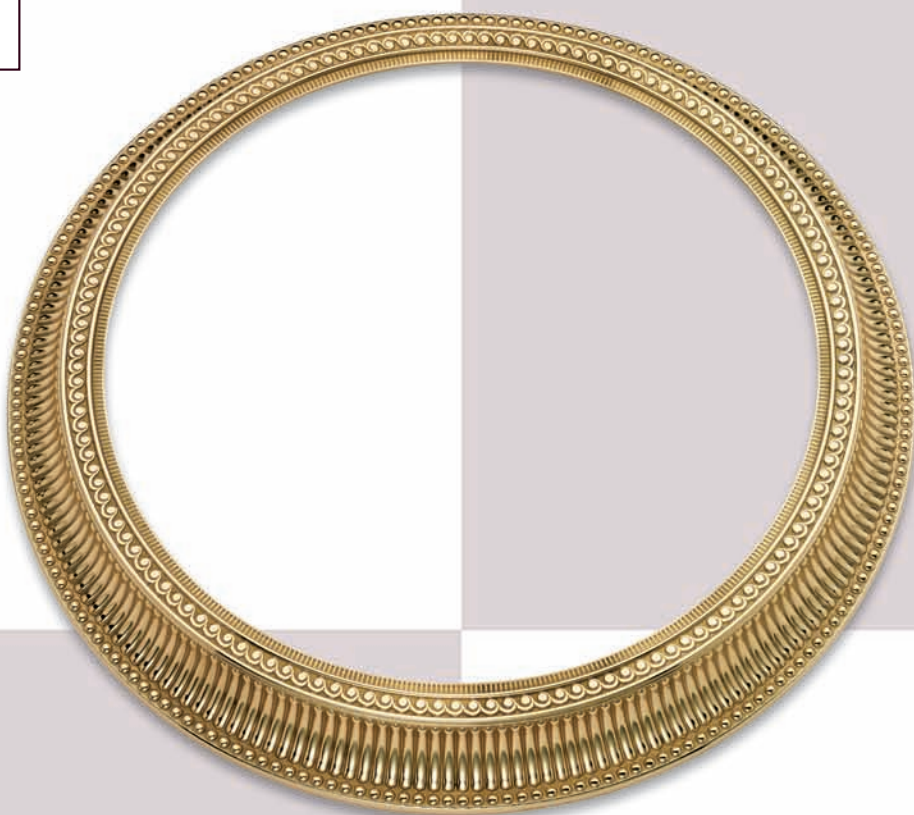

O.260

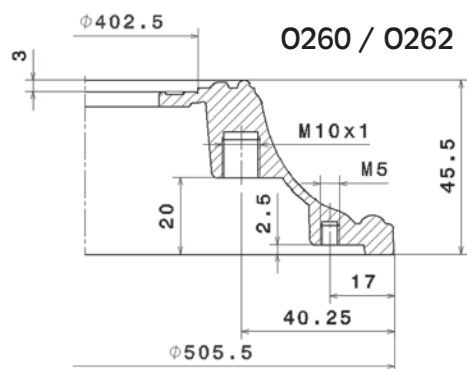

O.260 / O.262



4208



4209

ARTICOLO ITEM	Ø MAX	Ø VETRO GLASS	H	FILETTI THREADS
O 259	406	300	46	n. 6 10x1 + n. 4 M5
O 260	506	400	46	n. 6 10x1 + n. 4 M5
O 261	406	300	46	n. 6 10x1 + n. 4 M5
O 262	506	400	46	n. 6 10x1 + n. 4 M5
4208	300		38	Vetro molato
4209	400		55	Vetro molato



O.261



O.262



O.247



O.246



4222

338

ARTICOLO ITEM	Ø MAX	Ø INT.	H	FILETTI THREADS
O 246	160	89	37	n. 3 M4
O 247	160	89	37	n. 3 M4
4222	120	85	92	vetro



O

O

340



O.1002



O.1001

ARTICOLO ITEM		Ø	H	FLETTO THREAD
O 1001	Torn.	120	45	10x1
O 1002		220	40	10x1



O.1008



O.1007



O.1005



O.1006

ARTICOLO ITEM	Ø	H	FLETTO THREAD
------------------	---	---	------------------

O 1005	162	45	10x1
O 1006	120	40	10x1
O 1007	200	55	10x1
O 1008	300	83	10x1

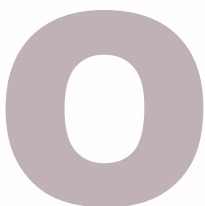



O.1004



O.1010

ARTICOLO ITEM	Ø	H	FORO/HOLE
O 1004	300	230	10,5
O 1009	145	100	10,5
O 1010	200	140	10,5



O.1009