

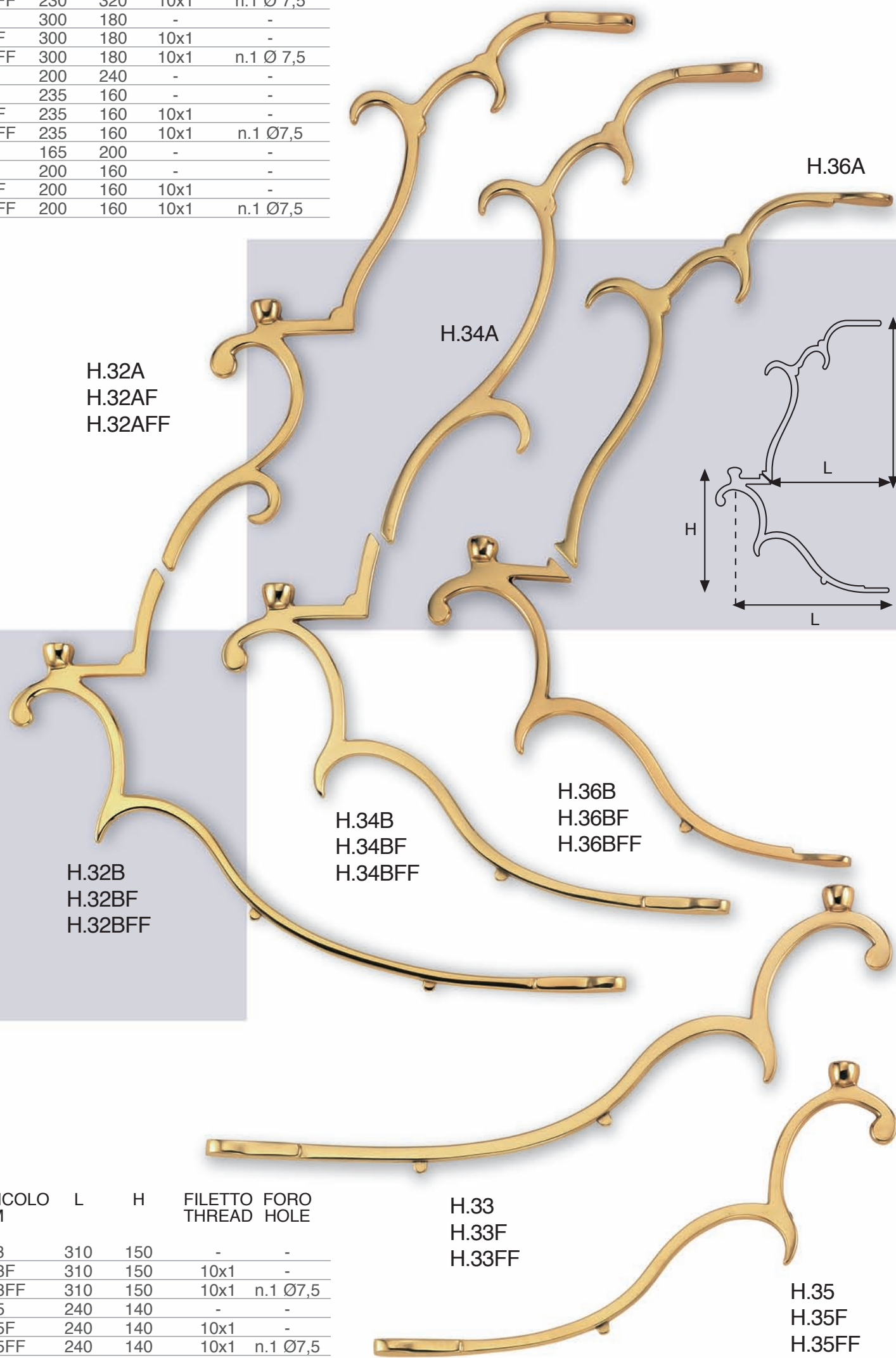

ARTICOLO ITEM	L	H	FILETTO THREAD	FORO HOLE
H 32/A	230	320	-	-
H 32/AF	230	320	10x1	-
H 32/AFF	230	320	10x1	n.1 Ø 7,5
H 32/B	300	180	-	-
H 32/BF	300	180	10x1	-
H 32/BFF	300	180	10x1	n.1 Ø 7,5
H 34/A	200	240	-	-
H 34/B	235	160	-	-
H 34/BF	235	160	10x1	-
H 34/BFF	235	160	10x1	n.1 Ø7,5
H 36/A	165	200	-	-
H 36/B	200	160	-	-
H 36/BF	200	160	10x1	-
H 36/BFF	200	160	10x1	n.1 Ø7,5

136



ARTICOLO ITEM	L	H	FILETTO THREAD	FORO HOLE
H 33	310	150	-	-
H 33F	310	150	10x1	-
H 33FF	310	150	10x1	n.1 Ø7,5
H 35	240	140	-	-
H 35F	240	140	10x1	-
H 35FF	240	140	10x1	n.1 Ø7,5

H.33
H.33F
H.33FF

H.35
H.35F
H.35FF

ARTICOLO ITEM	L	H	FILETTO THREAD
H 40	195	165	n° 2 10x1
H 49*	225	270	n° 2 10x1
H 50*	150	180	n° 2 10x1

* n. 2 fori / holes Ø 6,5



138



H.117



H.144



H.272



H.227-B



H.448

ARTICOLO ITEM	L	H	FILETTO THREAD
H 117	450	170	n° 3 10x1
H 144	115	145	n° 1 10x1
H 227-B	90	40	n° 2 10x1
H 272	150	210	n° 1 10x1
H 448	180	105	n° 2 10x1

ARTICOLO ITEM	L	H	FILETTO THREAD	IMPOSTA COUNTERSINK
H 184	125	220	10x1	10,2
H 184/FF	125	220	n.2 10x1	-
H 186	100	200	10x1	10,2
H 186/FF	100	200	n.2 10x1	-
H 187/FF	115	220	n.2 10x1	-
H 222	150	235	10x1	10,2
H 222/FF	150	235	n.2 10x1	-
H 223	105	245	10x1	10,2
H 223/FF	105	245	n.2 10x1	-



H.186
H.186FF

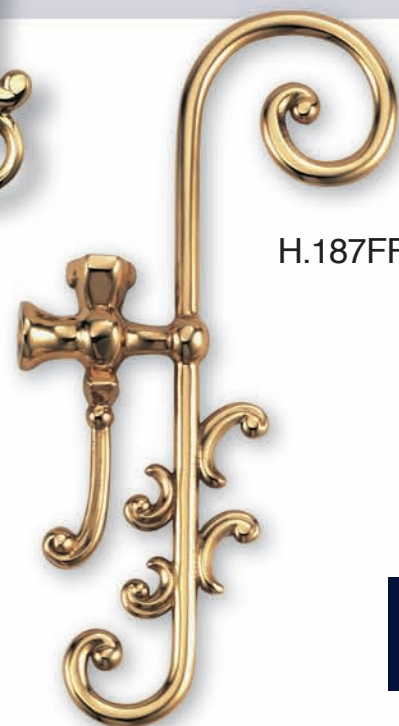

H.187FF



H.184
H.184FF



H.222
H.222FF



H.223
H.223FF



H.28
H.28FF
H.28-12



H.228



H.165FF
H.165
H.165-08



H.406



H. 188
H. 188FF



H.302
H.302FF



H.358F

140



H.383



H.384



H.516



H.181

ARTICOLO ITEM	L	H	FILETTO THREAD	FORO IMPOSTA COUNTERSINK
H 28	85	100	n.1 10x1	10,2
H 28-12	85	100	n.1 10x1	12,2
H 28FF	85	100	n.2 10x1	-
H 165	45	40	n.1 10x1	10,2
H 165-08	45	40	n.1 10x1	8,2
H 165FF	45	40	n.2 10x1	-
H 181	105	155	n.1 10x1	10,2
H 188	60	65	n.1 10x1	10,2
H 188FF	60	65	n.2 10x1	-
H 228	150	170	n.1 10x1	12,2
H 302	65	58	n.1 10x1	10,2
H 302FF	65	58	n.2 10x1	-
H 358F	40	35	n.1 10x1	no hole
H 383	67	50	n.2 10x1	-
H 384	60	50	n.2 10x1	-
H 406	87	60	n.2 10x1	-
H 516	50	60	n.2 10x1	-



H.151
H.151FF



H.197



H.282
H.282FF

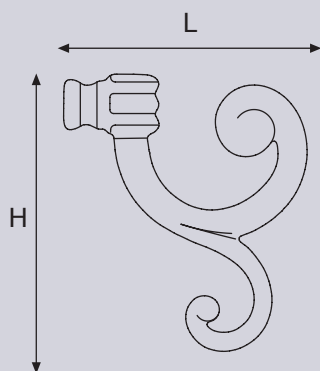

H.250
H.250FF



H.345
H.345FF



H.284
H.284FF

ARTICOLO ITEM	L	H	FILETTO THREAD	FORO IMPOSTA COUNTERSINK
H 151	90	100	n.1 10x1	10,2
H 151FF	90	100	n.2 10x1	-
H 197	70	55	n.1 10x1	10,2
H 250	70	70	n.1 10x1	10,2
H 250FF	70	70	n.2 10x1	-
H 282	65	100	n.1 10x1	10,2
H 282FF	65	100	n.2 10x1	-
H 284	75	120	n.1 10x1	10,2
H 284FF	75	120	n.2 10x1	-
H 345	55	70	n.1 10x1	10,2
H 345FF	55	70	n.2 10x1	-



H.226
H.226FF

H.251



H.266



H.267



H.265

ARTICOLO ITEM	L	H	FILETTO THREAD	FORO IMPOSTA COUNTERSINK
H 226	120	100	n.1 10x1	10,2
H 226FF	120	100	n.2 10x1	-
H 251	30	50		10,2
H 265	90	65	n.1 10x1	12,2
H 266	35	70		12,2
H 267	30	55	n.1 10x1	12,2
H 339	40	45	n.1 10x1	-
H 341 torn.	36	53	n.1 10x1	Foro / Hole 8
H 341F torn.	36	53	n.1 10x1	Foro / Hole 10,2
H 341FIL.	36	53	n.2 10x1	-
H 404	60	55	n.1 10x1	9
H 405	110	95	n.1 10x1	7



H.339



H.341
H.341F
H.341FIL



H.405



H.404



H.378



H.382



H.385



H.386



H.392



H.391

ARTICOLO ITEM	L	H	FILETTO THREAD
H 378	90	115	n.2 10x1
H 382	59	105	n.2 10x1
H 385	85	155	n.2 10x1
H 386	85	70	n.2 10x1
H 391	63	100	n.2 10x1
H 392	75	55	n.2 10x1



H.324



H.335



H.325

H.326
H.326FF



H.327



H.403FF



H.328

144

ARTICOLO ITEM	L	H	FILETTO THREAD	FORO IMPOSTA COUNTERSINK
H 324	90	180	n.1 10x1	10,2
H 325	70	145	n.1 10x1	10,2
H 326	100	205	n.1 10x1	10,2
H 326FF	100	205	n.2 10x1	-
H 327	85	165	n.1 10x1	10,2
H 328	75	115	n.1 10x1	10,2
H 335	90	140	n.1 10x1	10,2
H 403FF	100	170	n.2 10x1	-



H.280



H.287



H.292
H.292-10



H.293
H.293-12

ARTICOLO ITEM	L	H	FILETTO THREAD
H 280	150	250	-
H 287	125	165	-
H 292	60	320	-
H 292-10	60	320	n.2 10x1 + Ø 10,2
H 293	60	275	-
H 293-12	60	275	n.2 10x1 + Ø 12,2





H.81



H.82



H.83



H.84



H.174

ARTICOLO ITEM		L	H	FILETTO THREAD
H 81	▽	235	235	n.2 10x1
H 82	▽	195	190	n.2 10x1
H 83	▽	132	130	n.2 10x1
H 84	▽	90	75	n.2 10x1
H 174	▽	175	135	n.2 10x1



H.150



H.149

ARTICOLO ITEM	L	H	FILETTO THREAD
H 149 ▽	210	170	n.2 10x1
H 150 ▽	150	115	n.2 10x1
H 212 ▽	220	150	n.2 10x1
H 213 ▽	175	130	n.2 10x1
H 214 ▽	140	90	n.2 10x1



H.213



H.214



H.212



H.103



H.104



H.105

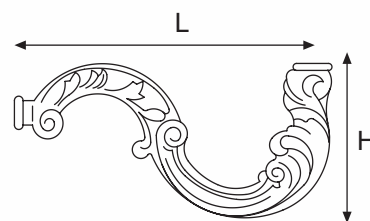

148

ARTICOLO ITEM	L	H	FILETTO THREAD
H 103 ▽	250	130	n.2 10x1
H 104 ▽	200	100	n.2 10x1
H 105 ▽	145	75	n.2 10x1



H.111



H.110



H.169



H.253

ARTICOLO ITEM	L	H	FILETTO THREAD
H 110 ▽	210	110	n.2 10x1
H 111 ▽	145	75	n.2 10x1
H 169 ▽	265	140	n.2 10x1
H 253 ▽	310	206	n.2 10x1

H



H.66



H.67



H.143



H.156



H.235



H.352



H.315



H.318

150

ARTICOLO ITEM	L	H	FILETTO THREAD
H 66 ▽	200	90	n.2 10x1
H 67 ▽	135	60	n.2 10x1
H 143 ▽	205	90	n.2 10x1
H 156 ▽	135	60	n.2 10x1
H 235 ▽	175	110	n.2 10x1
H 315 ▽	100	60	n.2 10x1
H 318 ▽	115	70	n.2 10x1
H 352 ▽	115	70	n.2 10x1



H.159

H.160



H.175



H.176



H.285

ARTICOLO ITEM	L	H	FILETTO THREAD
H 159 ▽	160	70	n.2 10x1
H 160 ▽	190	100	n.2 10x1
H 175 ▽	195	110	n.2 10x1
H 176 ▽	150	90	n.2 10x1
H 285 ▽	120	75	n.2 10x1

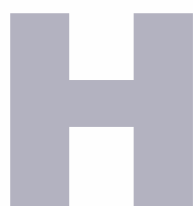

ARTICOLO ITEM	L	H	FILETTO THREAD
H 224 ▽	210	215	n.2 10x1
H 238 ▽	140	145	n.2 10x1

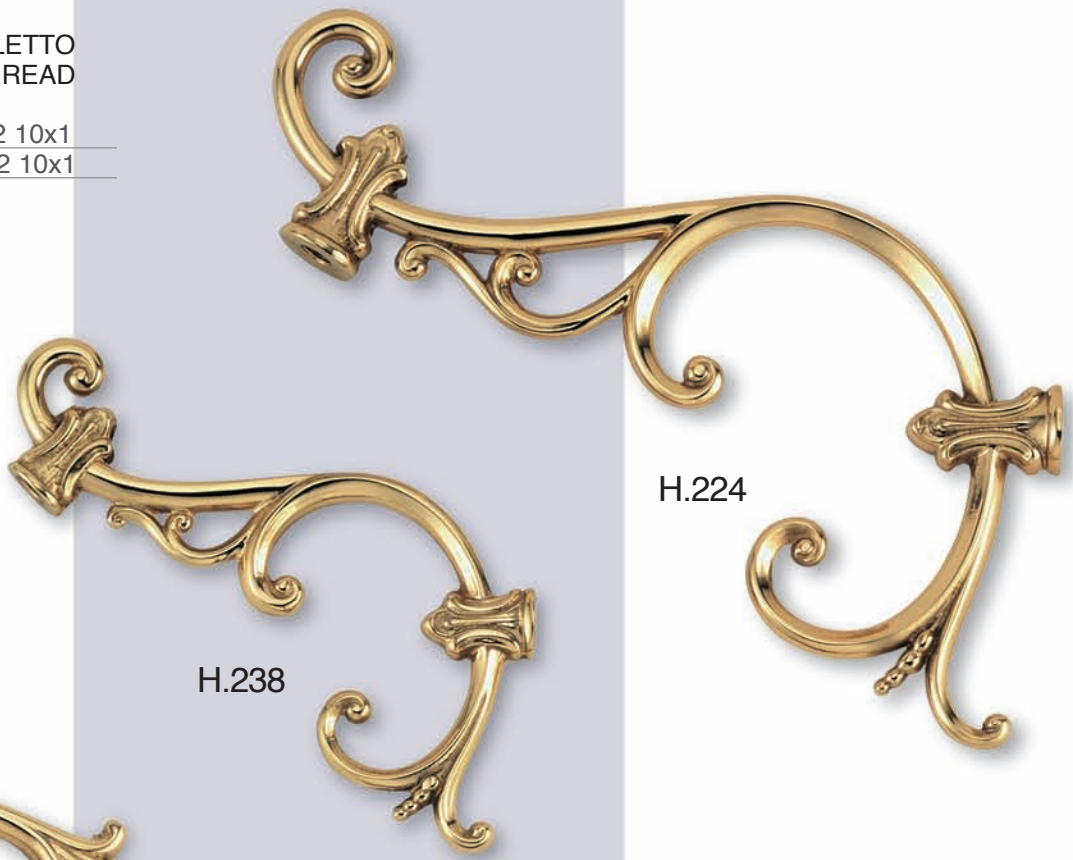

H.224

H.238

152



H.277



H.242



H.244

ARTICOLO ITEM	L	H	FILETTO THREAD
H 242 ▽	170	160	n.2 10x1
H 244 ▽	165	160	n.2 10x1
H 277 ▽	120	110	n.2 10x1

ARTICOLO ITEM	L	H	FILETTO THREAD
H 217 ▽	165	175	n.2 10x1
H 232 ▽	135	125	n.2 10x1
H 333 ▽	175	160	n.2 10x1

H.232



H.217



H.333

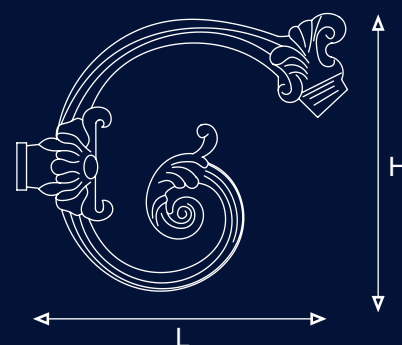
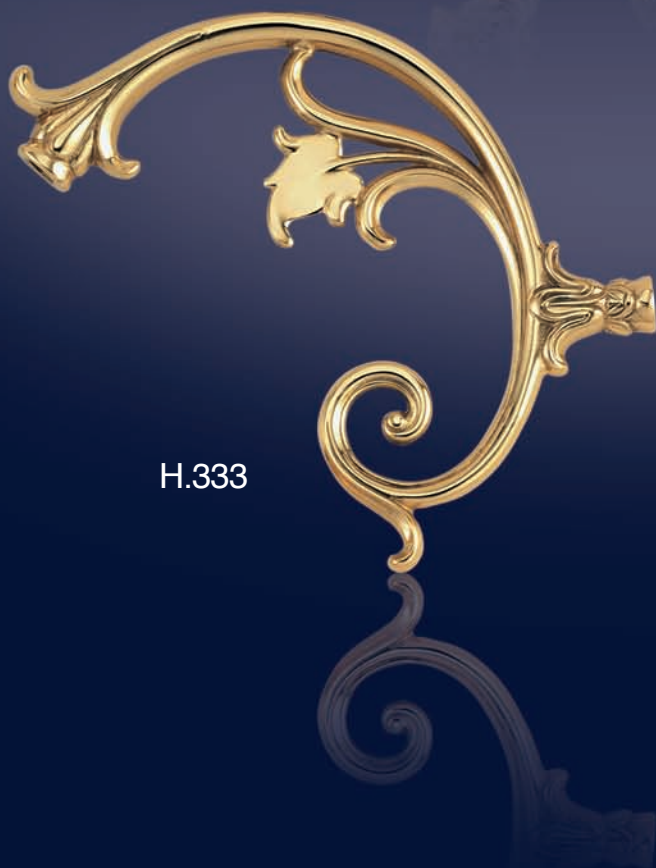



H.269



H.332

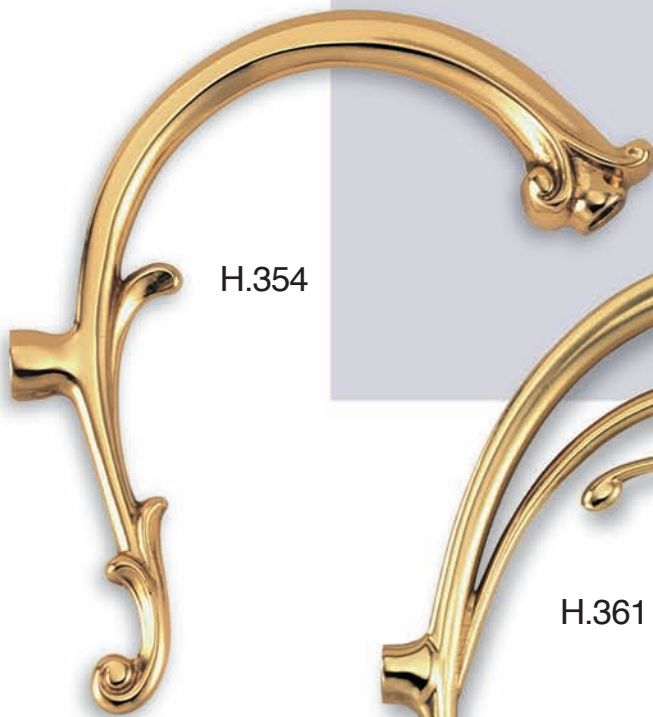

H.354

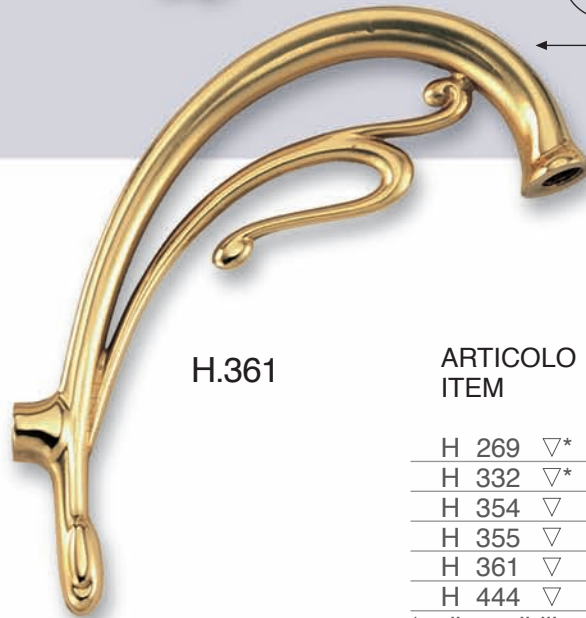

H.361

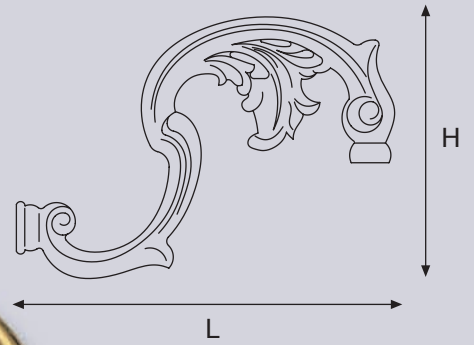

ARTICOLO L H FILETTO
ITEM

H 269 ▽* 160 110 n.2 10x1

H 332 ▽* 120 100 n.2 10x1

H 354 ▽ 140 170 n.2 10x1

H 355 ▽ 100 135 n.2 10x1

H 361 ▽ 120 150 n.2 10x1

H 444 ▽ 130 130 n.2 10x1

* disponibili anche con tubo interno pag 180
available also with internal tube pag 180



H.355



H.444



H.319



H.368



H.367

ARTICOLO ITEM	L	H	FILETTO THREAD
H 319 ▽	120	125	n.2 10x1
H 367 ▽	122	95	n.2 10x1
H 368 ▽	165	120	n.2 10x1
H 413 ▽	165	145	n.2 10x1
H 416 ▽	120	100	n.2 10x1



H.413



H.416



H.478



H.477



H.436



H.435

ARTICOLO ITEM	L	H	FILETTO THREAD
H 435* ▽	135	90	n.2 10x1
H 436* ▽	160	105	n.2 10x1
H 477 ▽	140	140	n.2 10x1
H 478 ▽	175	175	n.2 10x1

* Con perno anti rotazione
With counter-rotation-pin

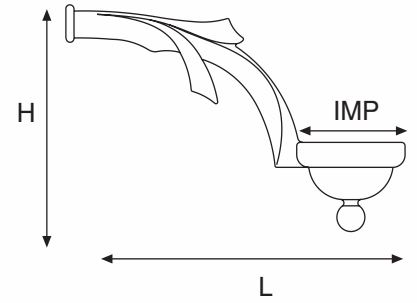

H.434

ARTICOLO ITEM	L	H	IMP	FILETTO THREAD
H 434 ▽	165	120	Ø 57,2	n.2 10x1
H 452 ▽	125	95	-	n.2 10x1



H.452 (IN PEZZI)



H.452



dx



sx

H



H.21



H.22



H.23



H.24

ARTICOLO ITEM	L	H	FILETTO THREAD
H 21	255	100	n.2 10x1
H 22	215	85	n.2 10x1
H 23	175	70	n.2 10x1
H 24	125	55	n.2 10x1



H.25
H.25-12



H.379



H.26



H.27

ARTICOLO ITEM	L	H	IMPOSTA COUNTERSINK	FILETTO THREAD
H 25 <input type="checkbox"/>	155	200	10,2	n.1 10x1
H 25-12 <input type="checkbox"/>	155	200	12,2	n.1 10x1
H 26 <input type="checkbox"/>	110	175	10,2	n.1 10x1
H 27 <input type="checkbox"/>	90	130	10,2	n.1 10x1
H 379 <input type="checkbox"/>	105	180	12,2	n.1 10x1
H 426 <input type="checkbox"/>	80	95	-	n.2 10x1
H 432 <input type="checkbox"/>	55	65	-	n.2 10x1
H 432-C	55	65	-	n.2 10x1 ciechi



H.432
H.432-C



H.426



H.331



H.131



H.118

160

ARTICOLO ITEM	L	H	FILETTO THREAD
H 118	220	145	n.2 10x1
H 131	265	190	n.2 10x1
H 331	325	235	n.2 10x1



H.119

ARTICOLO ITEM	L	H	FILETTO THREAD
H 119	195	140	n.2 10x1
H 132	160	115	n.2 10x1
H 268	118	108	n.2 10x1



H.132



H.268



H

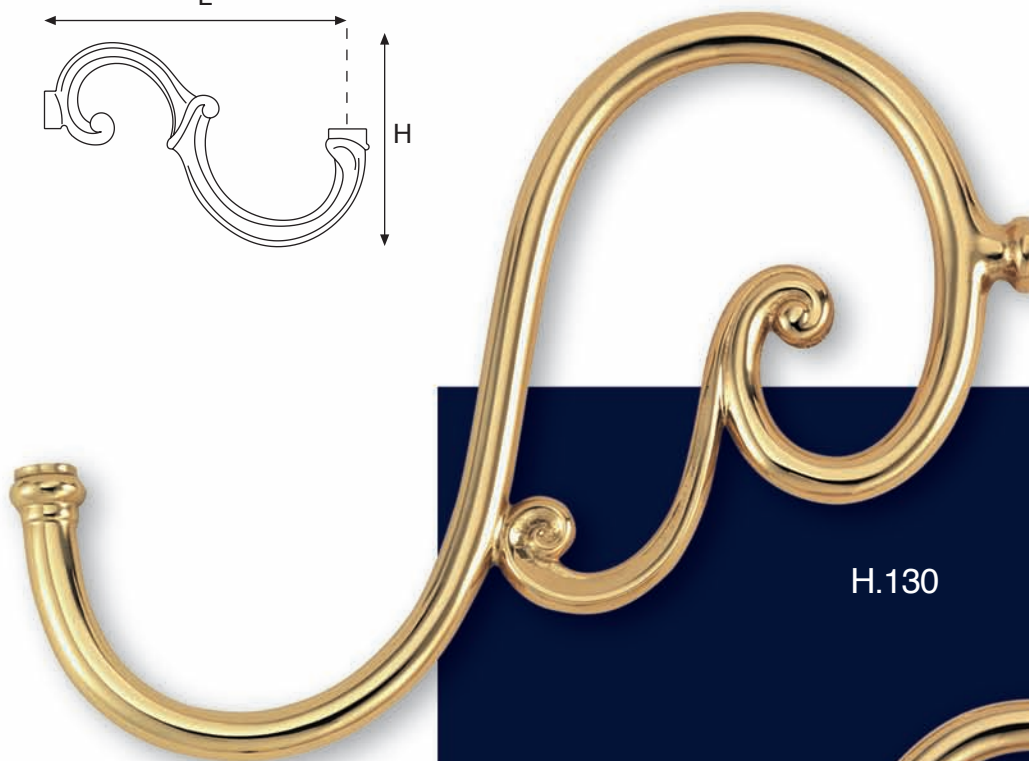
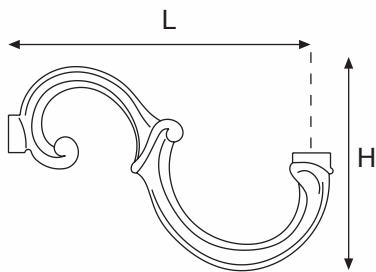

H.130



H.120



H.121

162

ARTICOLO ITEM	L	H	FILETTO THREAD
H 120 ☐	210	145	n.2 10x1
H 121 ☐	150	105	n.2 10x1
H 130 ☐	255	185	n.2 10x1



H.365



H.154



H.234

ARTICOLO ITEM	L	H	IMPOSTA COUNTERSINK	FILETTO THREAD
H 154	350	225	-	n.2 10x1
H 234	225	160	-	n.2 10x1
H 365	140	160	18,2	n.1 10x1

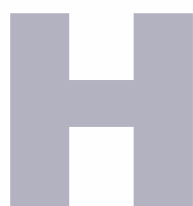



H.127



H.126



H.125



H.243

164

ARTICOLO ITEM	L	H	FILETTO THREAD
H 125 ☐	290	120	n.2 10x1
H 126 ☐	200	85	n.2 10x1
H 127 ☐	135	60	n.2 10x1
H 243 ☐	225	100	n.2 10x1



H.219



H.220



H.221

ARTICOLO ITEM	L	H	FILETTO THREAD
H 219 ☐	155	85	n.2 10x1
H 220 ☐	220	105	n.2 10x1
H 221 ☐	275	140	n.2 10x1



166

ARTICOLO ITEM	L	H	FILETTO THREAD
G 7 Torn.	32	47	n.1 10x1
H 203	225	180	n.2 10x1
H 205*	310	590	n.2 10x1

(*) in due pezzi / in two pieces



H.202

G.7



H.204

ARTICOLO ITEM	L	H	FILETTO THREAD
G 7 Torn.	32	47	n.1 10x1
H 202* □	420	260	n.2 10x1
H 204* □	320	500	n.2 10x1

(*) in due pezzi / in two pieces

ARTICOLO ITEM		L	H	FILETTO THREAD
H 189	☐	205	200	n.2 10x1
H 198	☐	155	140	n.2 10x1
H 200	☐	240	190	n.2 10x1



H.200



H.198



H.189

ARTICOLO ITEM	L	H	FILETTO THREAD
------------------	---	---	-------------------

H 254	□	225	215	n.2 10x1
-------	---	-----	-----	----------

H 322	□	150	145	n.2 10x1
-------	---	-----	-----	----------

H 351	□	260	250	n.2 10x1
-------	---	-----	-----	----------



H.351



H.254



H.322





H.246

H.247

170



H.255

H.289

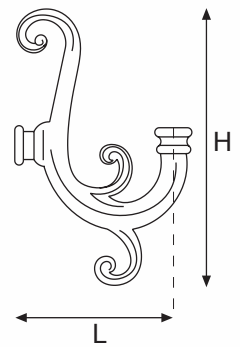

ARTICOLO ITEM		L	H	FILETTO THREAD
H 246	☐	145	125	n.2 10x1
H 247	☐	215	195	n.2 10x1
H 255	☐	90	100	n.2 10x1
H 289	☐	85	155	n.2 10x1

ARTICOLO ITEM	L	H	FILETTO THREAD
H 298	215	80	n.2 10x1
H 299	216	160	n.2 10x1
H 320	140	130	n.2 10x1
H 321	180	160	n.2 10x1
H 336	140	100	n.2 10x1



H.298



H.336



H.299



H.321



H.320

H

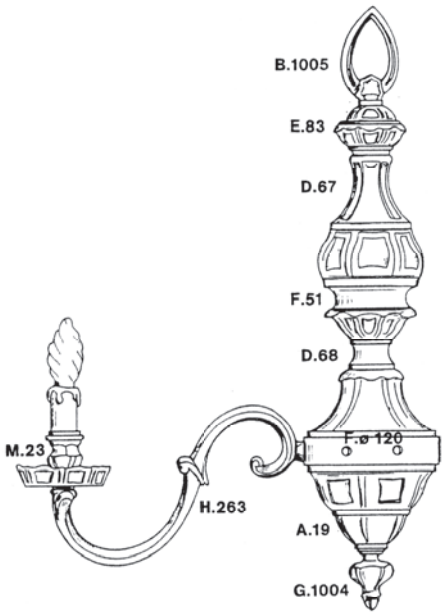

H.261



H.263



H.264

172

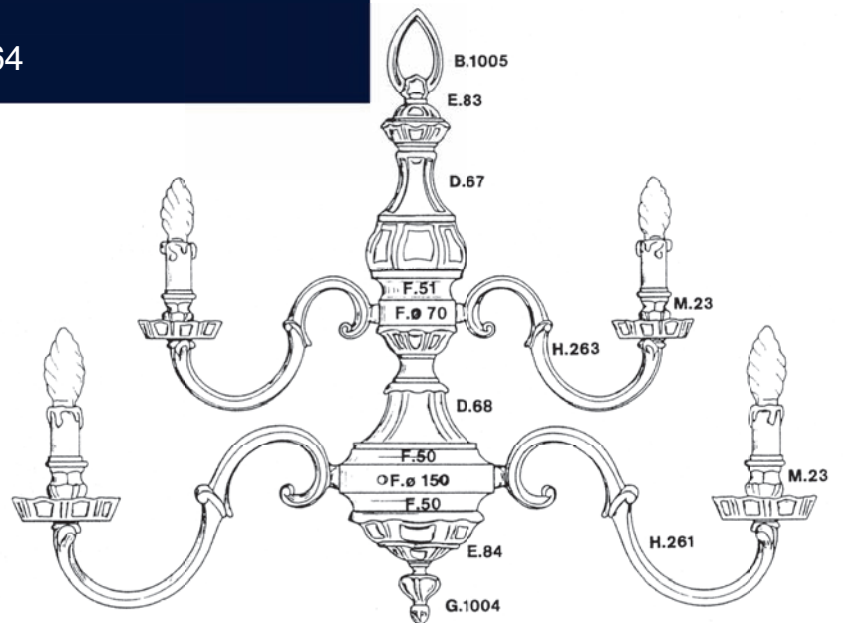

ARTICOLO ITEM	L	H	FILETTO THREAD
H 261	240	180	n.2 10x1
H 263	200	130	n.2 10x1
H 264	150	120	n.2 10x1

ARTICOLO ITEM	L	H	FILETTO THREAD
------------------	---	---	-------------------

H 342	215	165	n.2 10x1
H 343	285	240	n.2 10x1
H 356	180	145	n.2 10x1



H.342



H.343



H.356

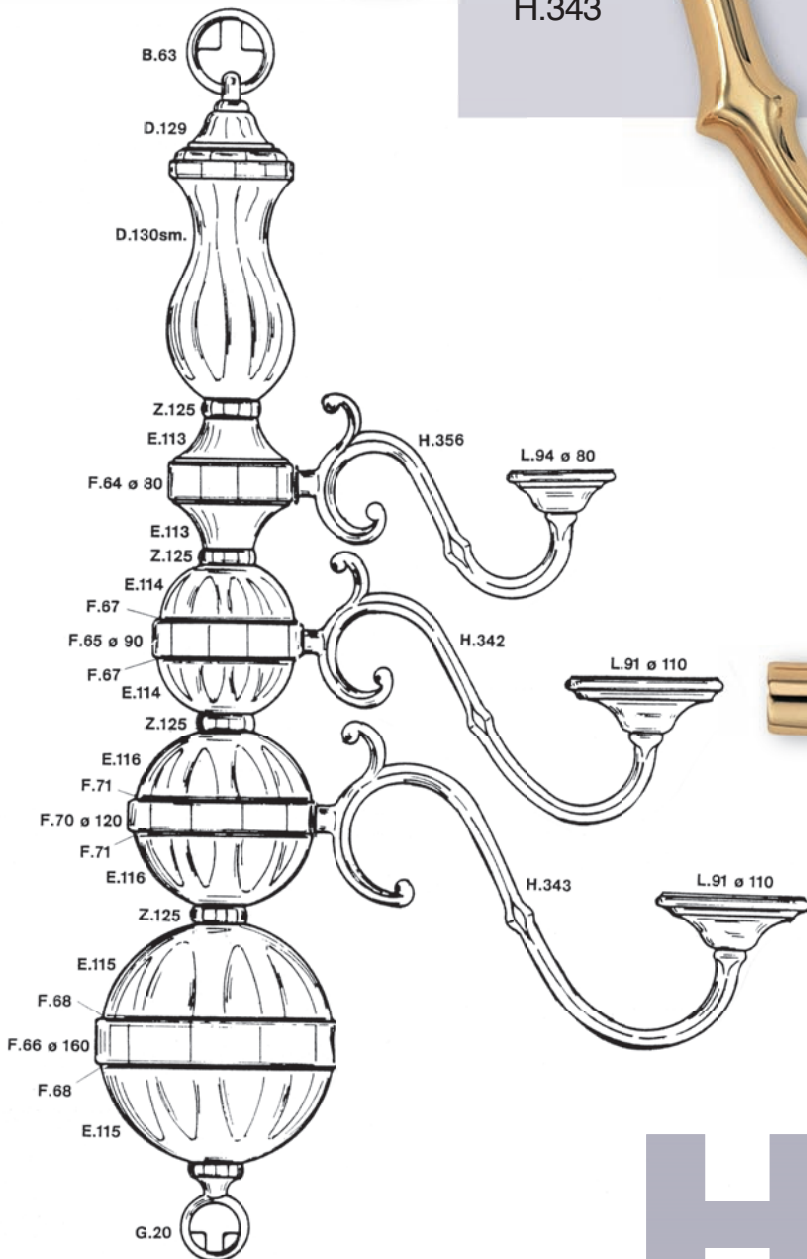



H.388



H.389



H.408



H.515

ARTICOLO ITEM		L	H	FILETTO THREAD
H 388	☐	165	55	n.2 10x1
H 389	☐	215	70	n.2 10x1
H 408	☐	270	80	n.2 10x1
H 515	☐	360	100	n.2 10x1

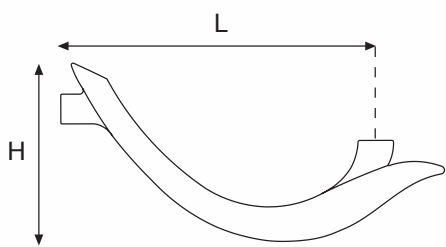

H.439



H.422

ARTICOLO ITEM	L	H	FILETTO THREAD
H 422	170	100	n.2 10x1
H 439	120	86	n.2 10x1
H 446	245	120	n.2 10x1
H 447	360	195	n.2 10x1



H.446

H.447

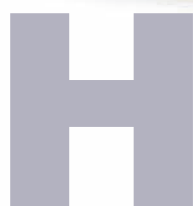

H



H.362

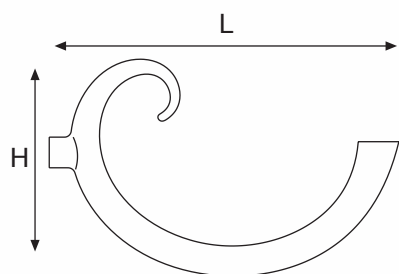

H.363



H.371

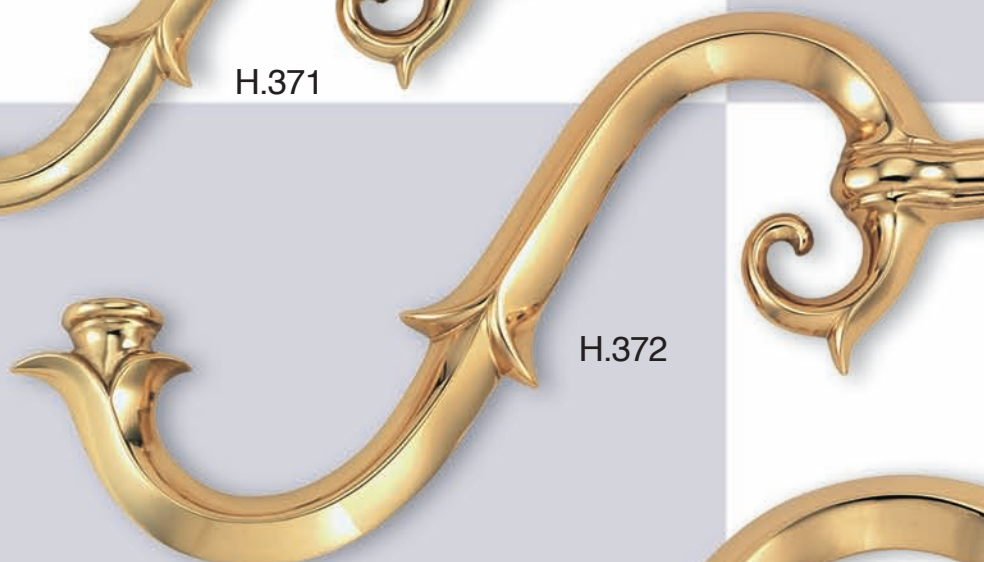

H.372



H.366

176

ARTICOLO ITEM	L	L1	H	FILETTO THREAD
H 362 ☐	125	115	80	n.2 10x1
H 363 ☐	170	160	110	n.2 10x1
H 366 ☐	320	280	185	n.2 10x1
H 371 ☐	180	160	105	n.2 10x1
H 372 ☐	255	220	130	n.2 10x1

ARTICOLO ITEM	L	L1	H	FILETTO THREAD
H 396	180	160	75	n.2 10x1
H 397	235	210	115	n.2 10x1
H 398	285	260	120	n.2 10x1
H 399	365	340	145	n.2 10x1



H.396

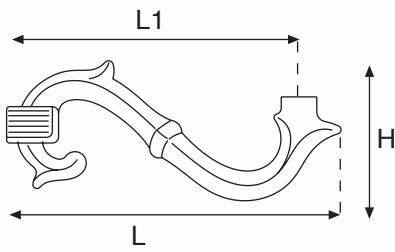

H.397



H.398



H.399



H.402

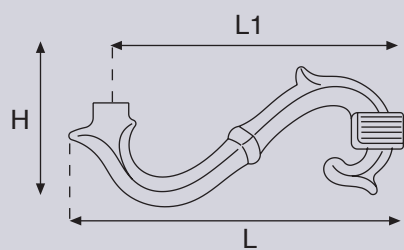

ARTICOLO ITEM	L1	L	H	FILETTO THREAD
H 400 ☐	170	200	100	n.2 10x1
H 401 ☐	220	260	120	n.2 10x1
H 402 ☐	280	330	155	n.2 10x1



H.401



H.400



H.466



H.467

ARTICOLO ITEM	L1	L	H	FILETTO THREAD
H 466 ☐	155	185	50	n.2 10x1
H 467 ☐	205	245	65	n.2 10x1
H 468 ☐	280	325	75	n.2 10x1
H 469 ☐	365	405	105	n.2 10x1



H.468



H.469

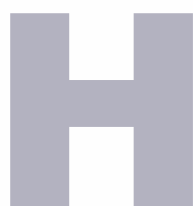



H.286



H.390

180



H.369

ARTICOLO ITEM		L	H	FILETTO THREAD
------------------	--	---	---	-------------------

H 286	☐	285	185	n.2 10x1
-------	---	-----	-----	----------

H 369 (*)	☐	160	105	n.2 10x1
-----------	---	-----	-----	----------

H 370 (*)	☐	120	80	n.2 10x1
-----------	---	-----	----	----------

H 390	☐	145	125	n.2 10x1
-------	---	-----	-----	----------

H 430	☐	62	70	n.2 10x1
-------	---	----	----	----------

(*) Vedi anche pag. 154 H.269 e H. 332 bracci con spacco

(*) See also page 154 H.269 e H. 332 items with open channel



H.370



H.430



H.373



H.428



H.427

ARTICOLO ITEM		L	H	FILETTO THREAD
H 373	☐	150	80	n.2 10x1
H 424	☐	180	165	n.2 10x1
H 427	☐	110	75	n.2 10x1
H 428	☐	115	85	n.2 10x1
H 429	☐	85	60	n.2 10x1



H.424



H.429



H.462



H.461



H.460

182

ARTICOLO ITEM		L	H	FILETTO THREAD
H 460	☐	165	100	n.2 10x1
H 461	☐	210	135	n.2 10x1
H 462	☐	265	170	n.2 10x1



H.307



H.276



H.288

ARTICOLO ITEM	L	H	FILETTO THREAD
H 276 (*)	175	180	n.2 10x1
H 288 (*)	225	240	n.2 10x1
H 307 (*)	120	120	n.2 10x1

(*) Not available for USA market





H.495



H.190



H.183

184

ARTICOLO ITEM		L	H	FILETTO THREAD
H 183	☐	125	115	n.2 10x1
H 190	☐	185	210	n.2 10x1
H 495	☐	135	165	n.2 10x1
H 431	☐	190	70	n.2 10x1
H 440	☐	110	50	n.2 10x1



H.440



H.431



H.506



H.194



H.162



H.494

ARTICOLO L H FILETTO
ITEM

H 162	☐	160	170	n.2 10x1
H 194	☐	120	140	n.2 10x1
H 494	☐	210	230	n.2 10x1
H 506	☐	85	95	n.2 10x1



ARTICOLO ITEM		L	H	FILETTO THREAD
H 445	☐	310	120	n.2 10x1
H 458	☐	150	60	n.2 10x1
H 459	☐	220	90	n.2 10x1



H.445

186



H.459



H.458



H.256



H.252

ARTICOLO ITEM		L	H	FILETTO THREAD
H 249	☐	180	165	n.2 10x1
H 252	☐	75	75	n.2 10x1
H 256	☐	85	60	n.2 10x1
H 257	☐	185	170	n.2 10x1
H 258	☐	122	122	n.2 10x1



H.249



H.258



H.257

H.410
H.410 FIL



H.414
H.414 FIL



H.412



ARTICOLO ITEM	L	H	Ø SUPERIORE Ø TOP	FILETTO THREAD
H 410	100	190	40	n.1 10x1
H 410 FIL	100	190	40	n.2 10x1
H 411	100	190	40	n.1 10x1
H 411 FIL	100	190	40	n.2 10x1
H 412	100	190	40	n.1 10x1
H 414	70	130	29	n.1 10x1
H 414 FIL	70	130	29	n.2 10x1
H 415	70	130	29	n.1 10x1
H 415 FIL	70	130	29	n.2 10x1

H.411
H.411 FIL



H.415
H.415 FIL

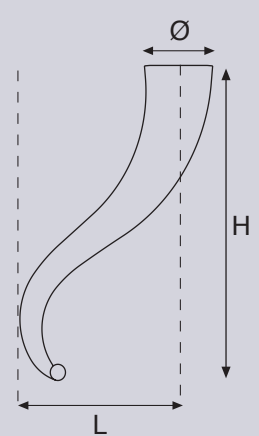

ARTICOLO ITEM	L	H	Ø SUPERIORE Ø TOP	FILETTO THREAD
H 451	135	95	48	n.2 10x1
H 463	150	190	50	n.2 10x1
H 465	95	150	50	n.2 10x1





H.442



H.514



Z.248



H.456



H.443

ARTICOLO ITEM	L	H	FILETTO THREAD
H 442	85	140	n.2 10x1
H 443	115	145	n.2 10x1
H 456	155	160	n.2 10x1
H 514	180	130	n.2 10x1
Z 248	60	35	Imposta mm 50



H.453



H.454

ARTICOLO ITEM		L	H	FILETTO THREAD
H 450	☐	90	95	n.1 10x1
H 453	☐	75	50	n.2 10x1
H 454	☐	80	65	n.2 10x1
H 455	☐	82	55	n.2 10x1
H 457	☐	70	45	n.2 10x1
H 513	☐	110	75	n.2 10x1



H.455



H.457

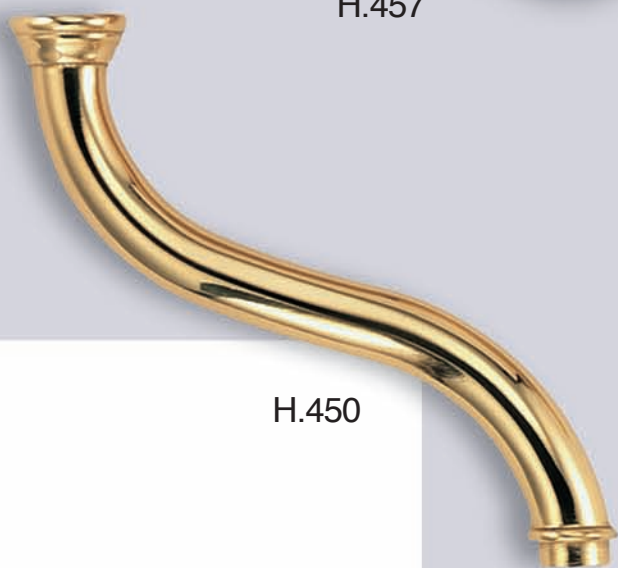

H.450



H.513





H.449

H.486



H.464

H.485

ARTICOLO ITEM		L	H	FILETTO THREAD
H 449	☐	110	86	n.1 10x1
H 464	☐	165	160	n.2 10x1
H 485	☐	110	110	n.2 10x1
H 486	☐	170	140	n.2 10x1



H.500



H.496

ARTICOLO ITEM	L	H	FILETTO THREAD	
H 496 ☐	L.V.	180	160	n.2 10x1
H 497 ▽	L.V.	180	160	n.2 10x1
H 500 ☐	L.V.	220	210	n.2 10x1

Vedi anche foglie a pag. 409
See also leaves on page n. 409



H.497



H



H.492



H.491

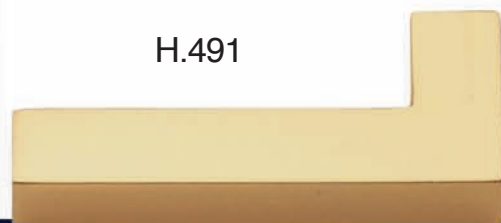

ARTICOLO ITEM		L	H	IMPOSTA TOP COUNTERSINK	FILETTO THREAD	PROFILO
H 491	□	95	40	-	n.2 10x1	□
H 492	□	95	40	-	n.2 10x1	○
H 493	□	95	40	-	n.2 10x1	□
Z 314		106	45	39	n.1 10x1 + 2 M3	
Z 315		106	45	39	n.1 10x1 + 2 M3	



H.493

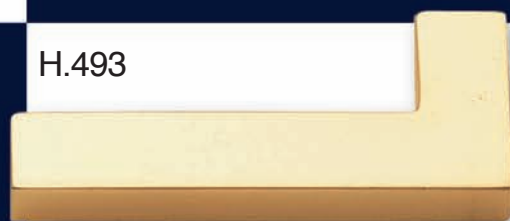

194

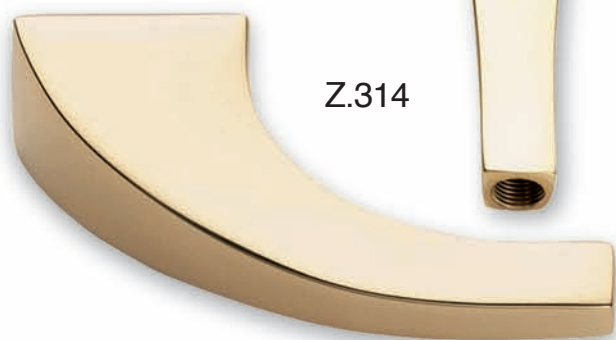



Z.314



Z.315



ARTICOLO ITEM	MISURE DIMENSIONS	FILETTO THREAD
H 503 FF 	93x60x14	n.2 10x1
H 504 FF 	143x60x14	n.2 10x1
H 505 FF 	193x60x14	n.2 10x1

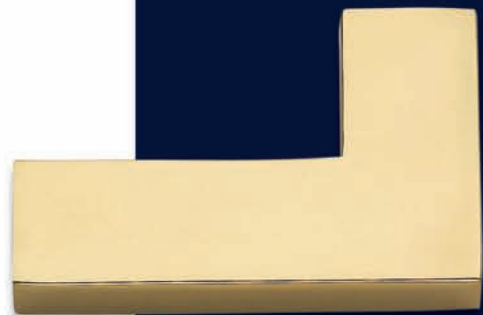

H.503 FF



H.504 FF



195



H.505 FF



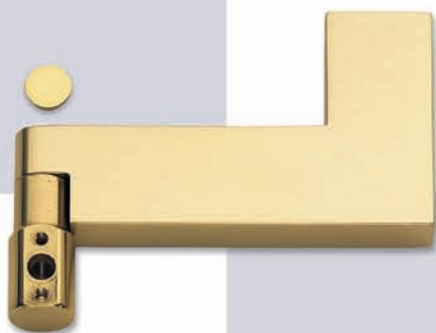

H.503 MS



H.504 MS



H.505 MS



H.504 MS



H.505 MS

ARTICOLO ITEM	MISURE DIMENSIONS	FILETTO THREAD
H 503 MS ☐	105x80x14	M4 + 10x1
H 504 MS ☐	155x80x14	M4 + 10x1
H 505 MS ☐	205x80x14	M4 + 10x1



K.43

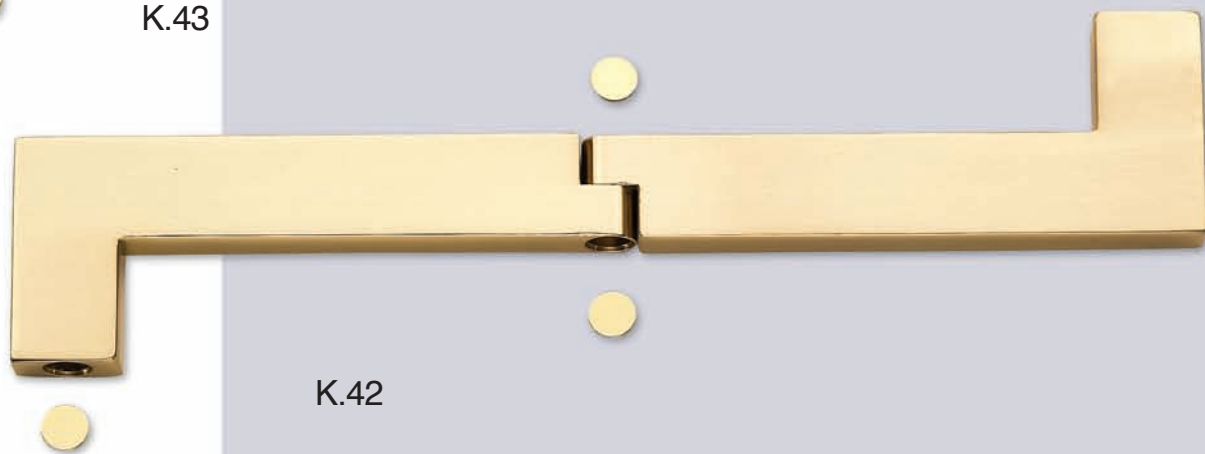

K.42

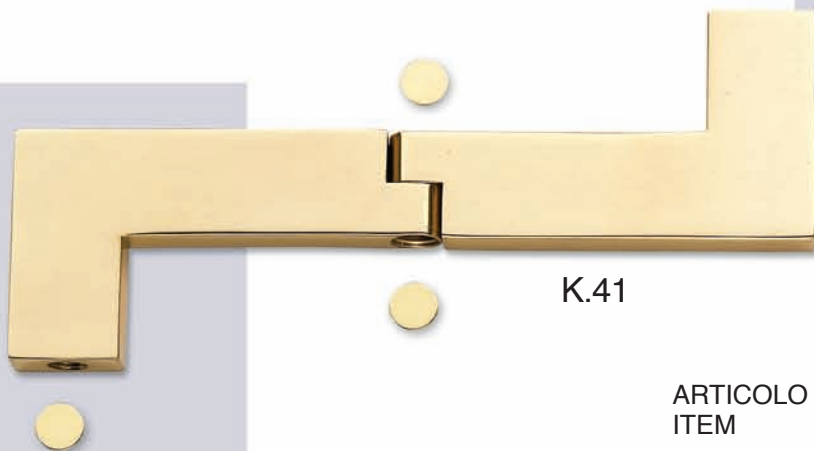

K.41



ARTICOLO ITEM	MISURE DIMENSIONS	FILETTO THREAD
K 41 <input type="checkbox"/>	195x90x14	M4 + 10x1
K 42 <input type="checkbox"/>	300x90x14	M4 + 10x1
K 43 <input type="checkbox"/>	395x90x14	M4 + 10x1

H

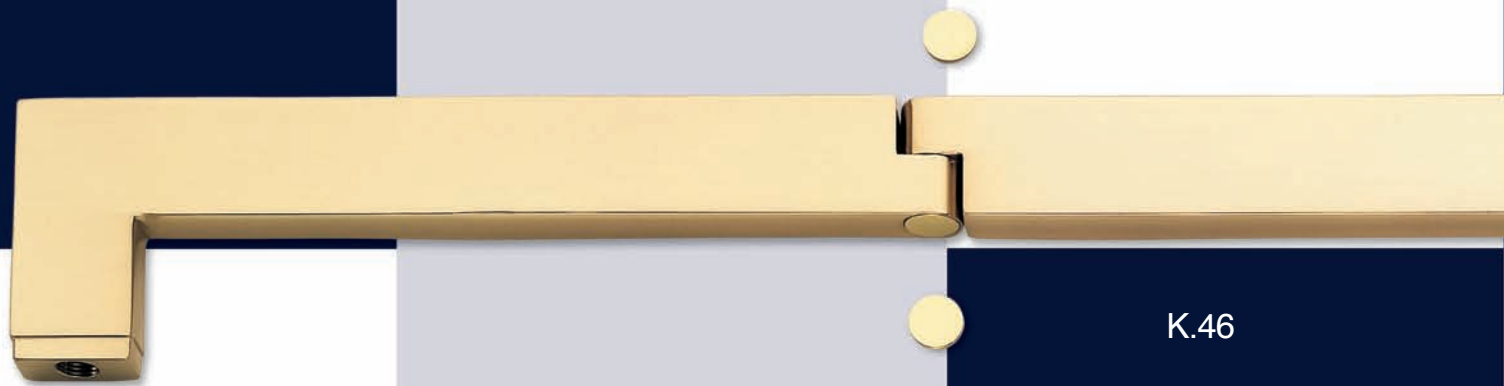

K.46



Z.329



Z.328



4158

198

ARTICOLO ITEM		MISURE DIMENSIONS	
Z 328	☐	90 x 27 x 14	
Z 329	☐	58 x 58 x 14	
4158		1200 x 27,4 x 14	TUBO/TUBE



K.45

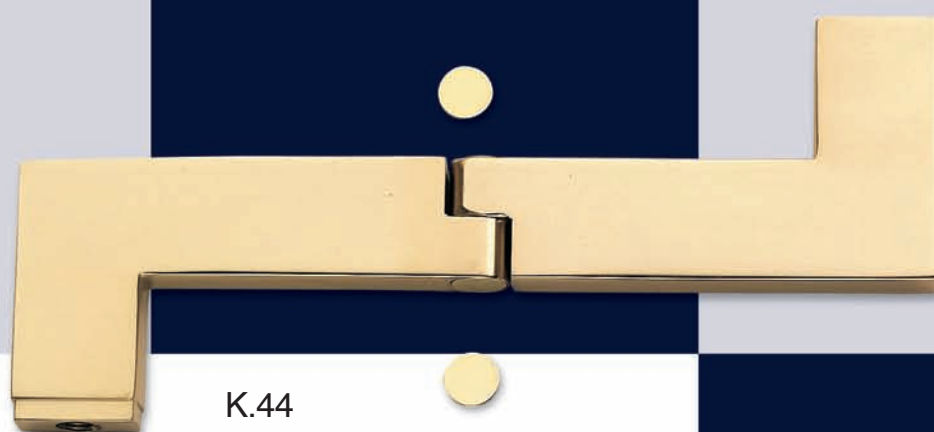

K.44

ARTICOLO ITEM	MISURE DIMENSIONS	FILETTO THREAD
K 44 <input type="checkbox"/>	195x90x14	n.2 10x1
K 45 <input type="checkbox"/>	300x90x14	n.2 10x1
K 46 <input type="checkbox"/>	395x90x14	n.2 10x1

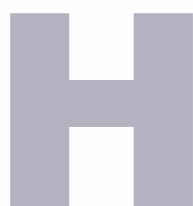



H.508



H.507



200



H.509



H.511



H.510



H.512

ARTICOLO ITEM	MISURE DIMENSIONS	FILETTO THREAD
(•)H 507 <input type="checkbox"/>	115x95	n.2 10x1
(•)H 508 <input type="checkbox"/>	195x145	n.2 10x1
(•)H 509 <input type="checkbox"/>	285x205	n.2 10x1
(•)H 510 <input type="checkbox"/>	400x260	n.2 10x1
(•)H 511 <input type="checkbox"/>	525x370	n.2 10x1
(•)H 512 <input type="checkbox"/>	100x320	n.2 10x1

(•) Not available for USA market

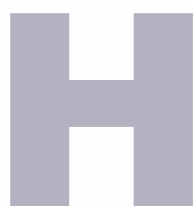



H.517

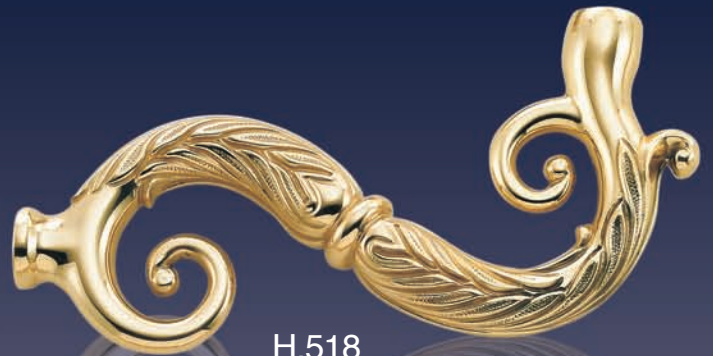

H.518





H.519

ARTICOLO ITEM	L	H	FILETTO THREAD
H 517 ☐	95	88	n.2 10x1
H 518 ☐	150	90	n.2 10x1
H 519 ☐	235	125	n.2 10x1



H.521

ARTICOLO ITEM	L	H	FILETTO THREAD
H 520 	300	140	n.2 10x1
H 521 	120	295	n.2 10x1



H.520





H.522



H.523



H.524

204

ARTICOLO ITEM	L	H	FILETTO THREAD
H 522 ☐	155	100	n.2 10x1
H 523 ☐	210	140	n.2 10x1
H 524 ☐	230	100	n.2 10x1



H.526



H.527



H.525

ARTICOLO ITEM	L	H	FILETTO THREAD
H 525 <input type="checkbox"/>	310	140	n.2 10x1
H 526 <input type="checkbox"/>	125	290	n.2 10x1
H 527 <input type="checkbox"/>	95	83	n.2 10x1

H.530



H.530-A



206



4219



4198



4215

4217

ARTICOLO ITEM	L	H	FORI/FILETTI HOLES/THREADS
H.530*	160	89	n.3 10x1
H.530-A*	160	89	n.3 10x1 + 2 M3
4198	12	6	Tappo/Cup 10x1
4215	copertura trasparente + 9 SMD LED 12V		
4217	Solo copertura trasparente - Only transparent cover		
4219	Alimentatore / Ballast 4W 12V 350mA (n.1 enough for n.6 4215 or n.5 4216)		

* Fornito con copertura e n.1 tappo filettato
 * Supplied with cover and n.1 threaded cup

ARTICOLO ITEM	L	H	FORI/FILETTI HOLES/THREADS
H.531*	220	120	n.3 10x1
H.531-A*	220	120	n.3 10x1 + 2 M3
H.532	44	22	In due pezzi/pieces 10x1
4216	copertura trasparente + 12 SMD LED 12V		
4218	Solo copertura trasparente - Only transparent cover		
4219	Alimentatore / Ballast 4W 12V 350mA (n.1 enough for n.6 4215 or n.5 4216)		

* Fornito con copertura e n.1 tappo filettato

* Supplied with cover and n.1 threaded cup

H.531



H.531-A



H.532



4218



4216



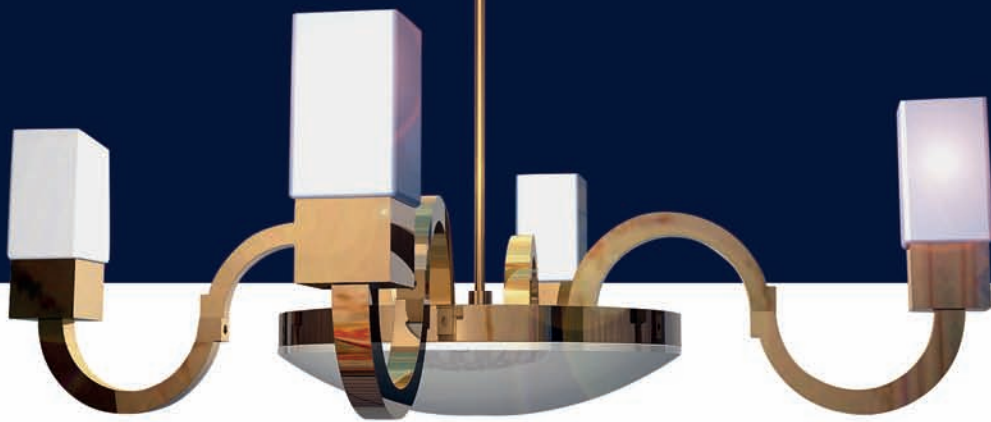

208

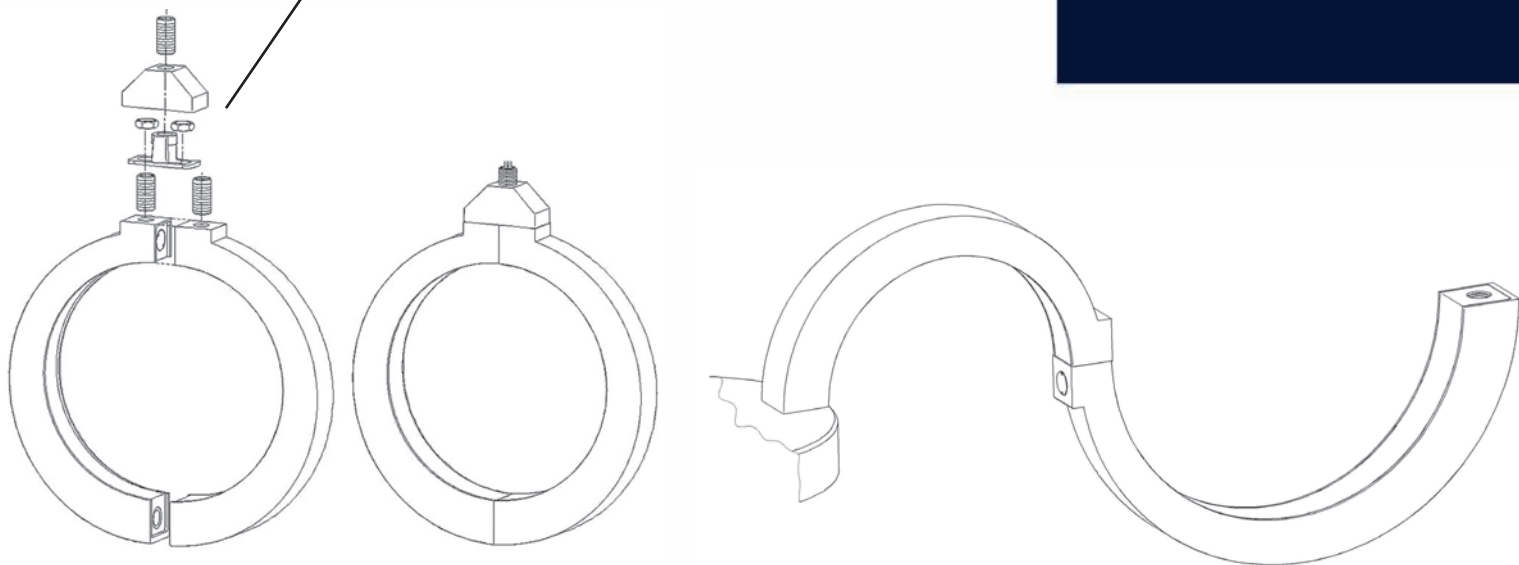
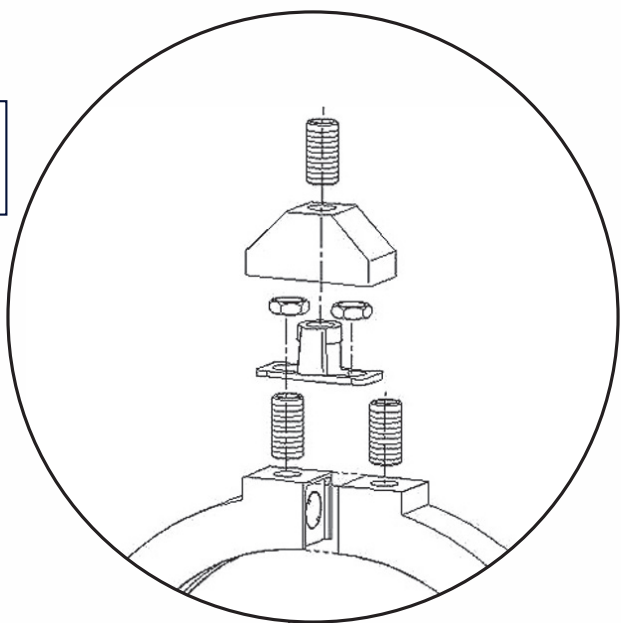

4201

Z.354

H.530-A
4215

R.63



R.158

H.530-A

R.157

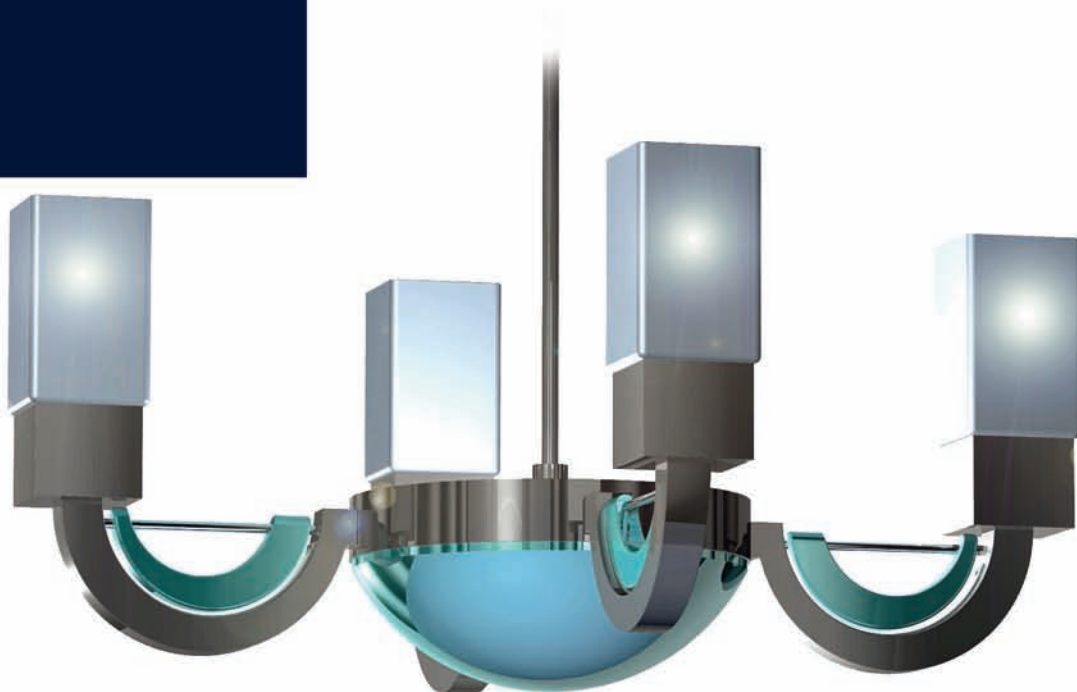



H.1003



H.1004



H.1010



H.1011

210

ARTICOLO ITEM	L	H	FILETTO THREAD
H 1003	200	100	n.2 10x1
H 1004	145	70	n.2 10x1
H 1010	145	75	n.2 10x1
H 1011	180	90	n.2 10x1
H 1013	120	90	n.2 10x1
H 1015	55	170	n.1 3/16

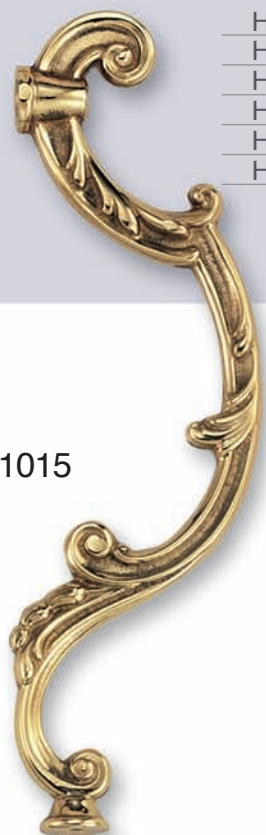

H.1015



H.1013

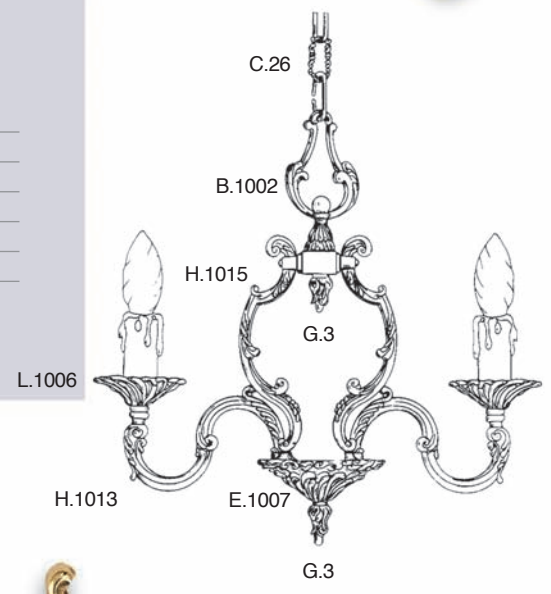

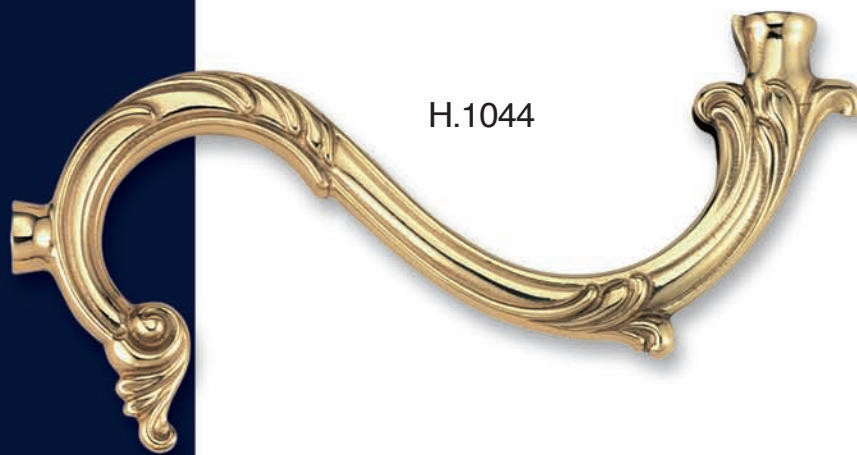

H.1044



H.1043

ARTICOLO ITEM	L	H	FILETTO THREAD
H 1043 ▽	105	45	n.2 10x1
H 1044 ▽	170	100	n.2 10x1
H 1068	130	80	n.2 10x1
H 1076	105	85	n.2 10x1
H 1073 ◻	130	80	n.2 10x1



H.1076



H.1068



H.1073

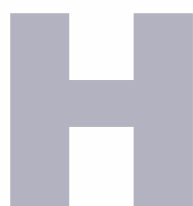



H.1002



H.1001



H.1000

ARTICOLO ITEM	L	H	FILETTO THREAD
H 1000 ☐	250	120	n.2 10x1
H 1001 ☐	180	95	n.2 10x1
H 1002 ☐	145	70	n.2 10x1

H.1093



ARTICOLO ITEM	L	H	FILETTO THREAD
H 1092 <input type="checkbox"/>	310	150	n.2 10x1
H 1093 <input type="checkbox"/>	120	260	n.2 10x1



H.1092



H.1049



H.1050



H.1051



H.1052



H.1061-B



H.1059

ARTICOLO ITEM	L	H	FILETTO THREAD
H 1049 ▽	140	55	n.2 10x1
H 1050 ▽	200	75	n.2 10x1
H 1051 (*) ▽	150	55	n.2 10x1
H 1052 (*) ▽	195	75	n.2 10x1
H 1059	55	55	n.2 10x1
H 1061-B	47	107	n.2 10x1

(*) Con copertura / Supplied with cover

ARTICOLO ITEM		L	H	FILETTO THREAD
H 1005	☐	140	90	n.2 10x1
H 1006	☐	190	130	n.2 10x1
H 1007	☐	240	155	n.2 10x1



H.1005



H.1006



H.1007

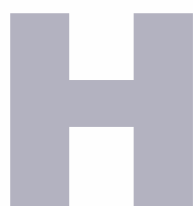



Grand Versaille a:
8+4 / 10+5 / 12+6 luci Ø 95 h. 76 cm

ARTICOLO ITEM	L	H	FILETTO THREAD
(•) H 1024 <input type="checkbox"/>	200	260	n.3 10x1
(•) H 1027 <input type="checkbox"/>	200	120	n.2 10x1
(•) H 1074 <input type="checkbox"/>	300	375	n.3 10x1
(•) H 1075 <input type="checkbox"/>	300	130	n.2 10x1
(•) H 1089 <input type="checkbox"/>	150	115	n.2 10x1
(•) H 1090 <input type="checkbox"/>	150	220	n.3 10x1

(•) Not available for USA market

216



H.1074



H.1075



H



H.1090



Versaille a: 5 / 3+3 luci Ø 60 h. 50 cm



H.1024



H.1089



H.1027



H.1025



H.1026



H.1038



H.1030



H.1034

218

ARTICOLO ITEM		L	H	FILETTO THREAD
H 1025	☐	220	170	n.2 10x1
H 1026	☐	150	95	n.2 10x1
H 1030	☐	65	70	n.2 10x1
H 1034	☐	125	55	n.2 10x1
H 1038	☐	285	160	n.2 10x1



H.1065



H.1072

ARTICOLO ITEM		L	H	FILETTO THREAD
H 1065	☐	100	145	n.2 10x1
H 1069	☐	125	50	n.2 10x1
H 1070	☐	220	80	n.2 10x1
H 1072	☐	82	130	n.2 10x1



H.1069



H.1070



H.513



H.1066



H.1067

ARTICOLO ITEM	L	H	FILETTI THREADS
H 513 <input type="checkbox"/>	110	75	n.2 10x1
H 1066 <input type="checkbox"/>	120	105	n.2 10x1
H 1067 <input type="checkbox"/>	220	125	n.2 10x1

ARTICOLO ITEM	L	H	FILETTI THREADS
(-) H 1079 <input type="checkbox"/>	300	150	n.2 10x1
(-) H 1080 <input type="checkbox"/>	365	175	n.2 10x1
(-) Not available for USA market			



H.1080



H.1079



H.1033



H.1032



H.1081

222

ARTICOLO ITEM		L	H	FILETTO THREAD
H 1032	☐	210	140	n.2 10x1
H 1033	☐	150	90	n.2 10x1
(.) H 1081	☐	300	180	n.2 10x1

(.) Not available for USA market

ARTICOLO ITEM		L	H	FILETTO THREAD
(.) H 1082	<input type="checkbox"/>	370	250	n.2 10x1
(.) H 1083	<input type="checkbox"/>	480	310	n.2 10x1
(.) Not available for USA market				



H.1083



H.1082



H.1036



H.1091



H.1035

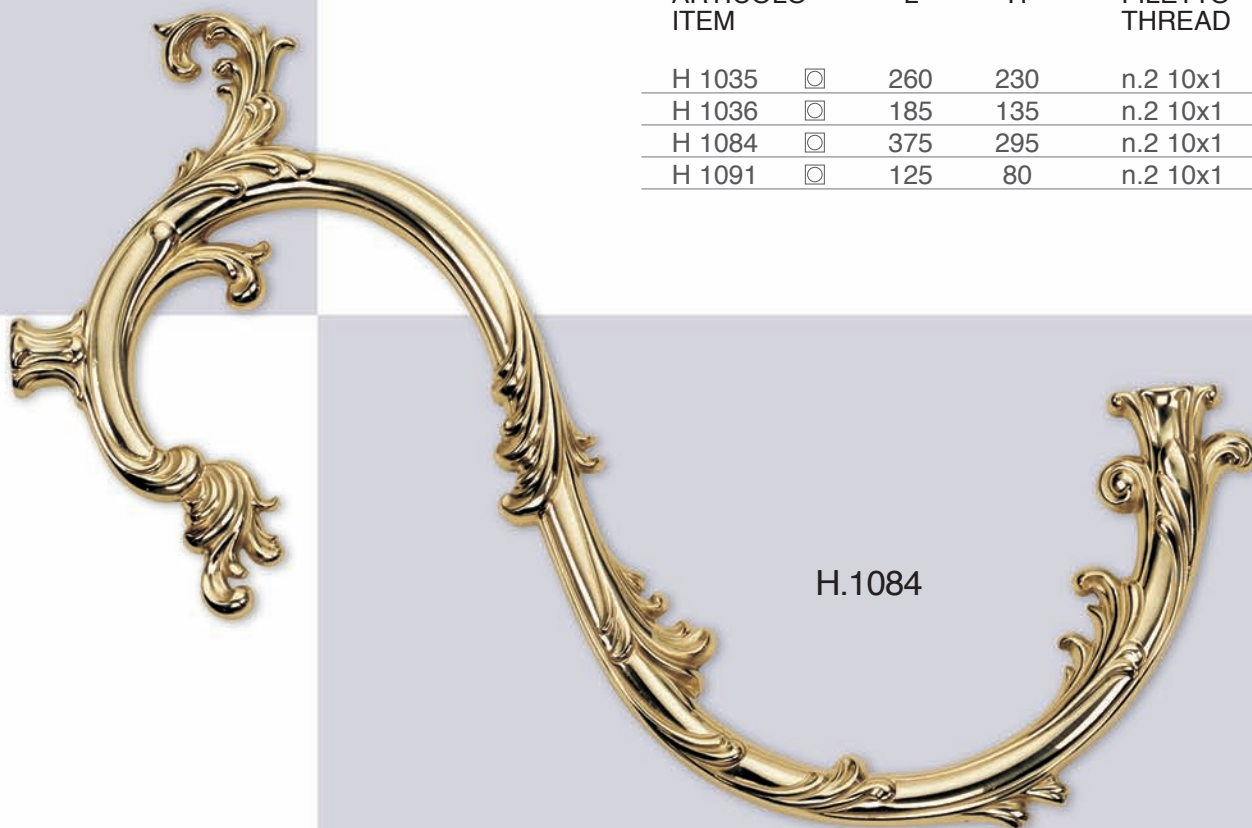

H.1084

ARTICOLO ITEM		L	H	FILETTO THREAD
H 1035	☐	260	230	n.2 10x1
H 1036	☐	185	135	n.2 10x1
H 1084	☐	375	295	n.2 10x1
H 1091	☐	125	80	n.2 10x1



H.1085



H.1085-B



H.1086

ARTICOLO ITEM	L	H	FILETTO THREAD
H 1085 <input type="checkbox"/>	220	250	n.2 10x1
H 1085-B <input type="checkbox"/>	200	220	n.2 10x1
H 1086 <input type="checkbox"/>	285	200	n.2 10x1

H



H.1088



H.1087



ARTICOLO ITEM		L	H	FILETTO THREAD
H 1087	☐	510	370	13x1 + 10x1
H 1088	☐	490	370	13x1 + 10x1





H.1019



H.1018

ARTICOLO ITEM		L	H	FILETTO THREAD
H 1018	☐	225	95	10x1
H 1019	☐	145	70	10x1
H 1047	☐	170	155	10x1
H 1048	☐	130	115	10x1
H 1071	☐	95	100	10x1



H.1048



H.1071



H.1047

ARTICOLO ITEM		L	H	FILETTO THREAD
H 1077	☐	160	85	10x1
H 1078	☐	220	110	10x1



H.1077



H.1078



BRACCI SNODATI IN OTTONE SWING ARMS IN SOLID BRASS

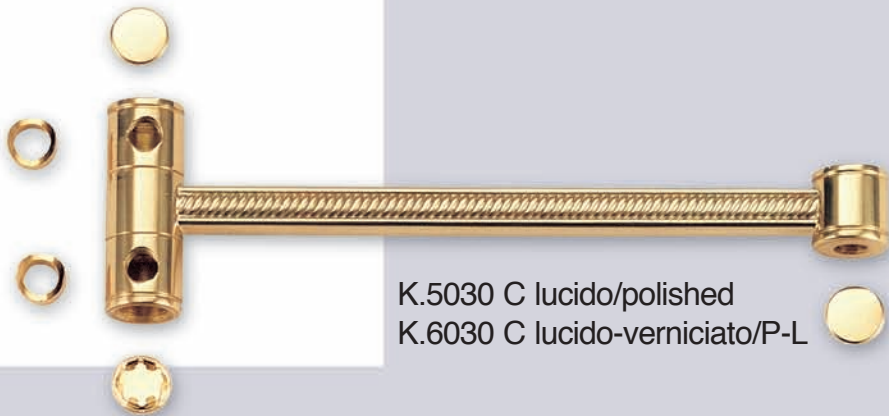

K.5030 C lucido/polished
K.6030 C lucido-verniciato/P-L

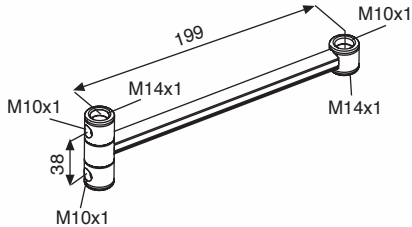

K.5030 C polished
K.6030 C P-L

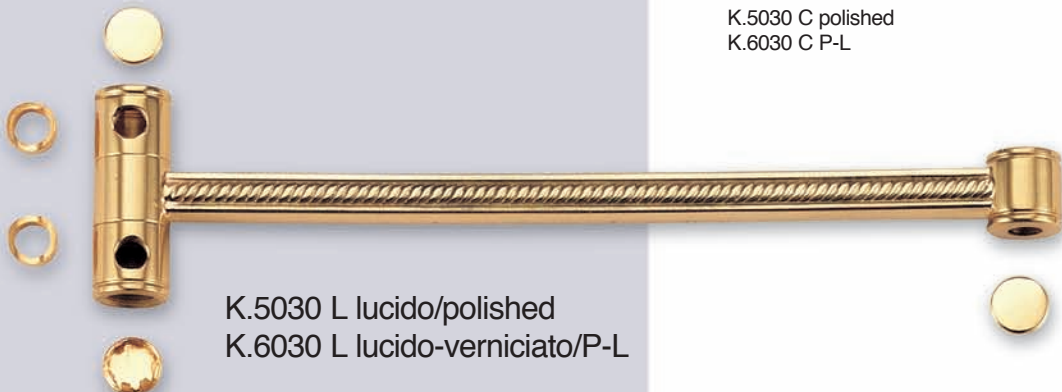

K.5030 L lucido/polished
K.6030 L lucido-verniciato/P-L

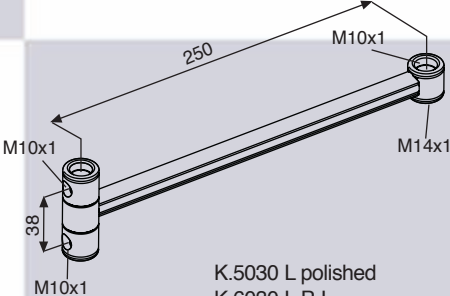

K.5030 L polished
K.6030 L P-L

230

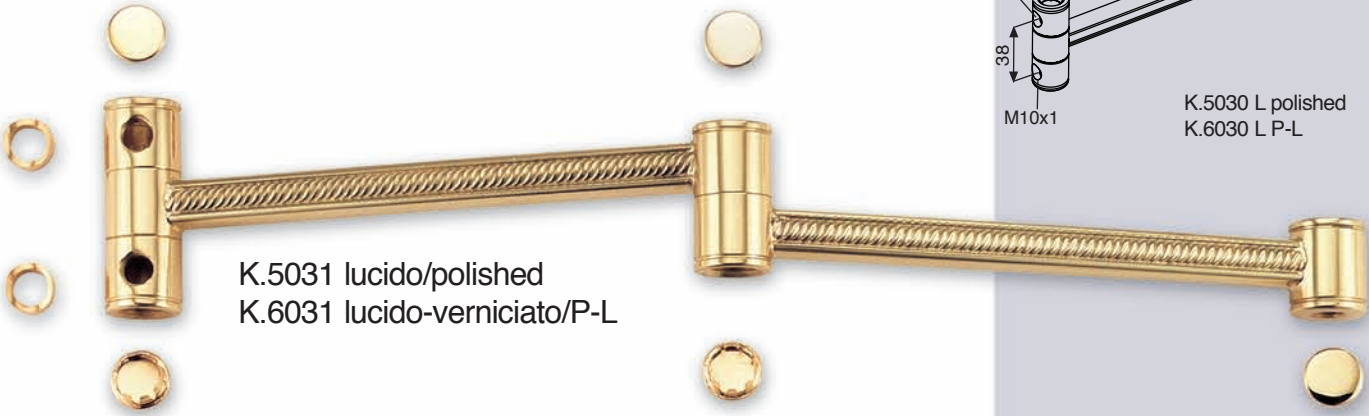

K.5031 lucido/polished
K.6031 lucido-verniciato/P-L

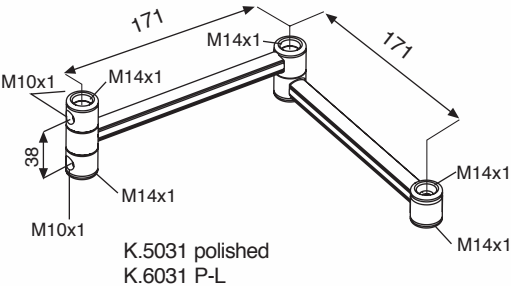

K.5031 polished
K.6031 P-L



K.5032 lucido/polished
K.6032 lucido-verniciato/P-L

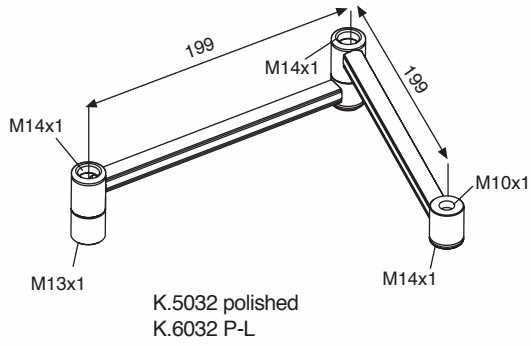

Z.231
FIL. 14x1 / 10x1

