

# Specification Datasheet

Copy right 20140617 / Ver B -

## Ergon COB 2530HE

- 62W maximum power capability
- High brightness LED
- Dimension : 23.85 x 23.85 x 2.35 mm
- Precondition : JEDEC Level 2a
- Lead-free reflow soldering application
- RoHS compliant



# Table of Contents

1. Product description .....	3
2. Absolute maximum ratings .....	3
3. Electro-optical characteristics( $T_a=25\text{ }^\circ\text{C}$ ) .....	4
4. Electro-optical chart( $T_a=25\text{ }^\circ\text{C}$ ) .....	4
5. Ranks .....	5
6. Chromaticity diagram & coordinates .....	6
7. Characteristic Graphs( $T_a=25\text{ }^\circ\text{C}$ ) .....	7-9
8. Outline Dimensions .....	10
9. Circuit Design .....	10
10. Reliability test items and conditions .....	11
12. Cautions .....	12-13

## 1. Product description

### (1) Description

- The Ergon series LED is designed for the high power operation to get the high flux output applications.
- It is ideal for the light source for general illumination applications, custom designed solutions.

### (2) Features

- Maximum drive current up to 1,600mA
- Low thermal resistance as low as 0.42°C/W
- Viewing angle of 120 degrees
- Precondition JEDEC Level 2a
- RoHS compliant

### (3) Applications

- Indoor lighting, Outdoor lighting, Industrial lighting

## 2. Absolute maximum ratings

Parameters	Symbol	Value	Unit
Power dissipated	Pd	62	W
Rated forward current	If	1,600	mA
Maximum junction temperature capability(1)	Tj	125	°C
Operating temperature	Top	- 40 ~ +85	°C
Storage temperature	Tst	- 40 ~ +100	°C

- (1) Proper current derating must be observed to maintain junction temperature below the maximum.

**3. Electro-optical characteristics (Ta=25°C)**

Parameters	Symbol	If(mA)	Typ.	Unit
Forward voltage	Vf	800	37.0	V
Viewing angle FWHM	2θ1/2	800	120	degrees
Thermal resistance junction to solder pad	Rthj-s		0.42	°C/W

- Lumens maintains a tolerance of ±3% on forward voltage measurements.

**4. Electro-optical chart (Ta=25°C)**

CCT(K)	CRI	If(mA)	Vf(V)	Pd(W)	Typ. Φv(lm)	lm/W
2700	80	800	37.0	29.6	3200	108
3000		800	37.0	29.6	3450	117
3500		800	37.0	29.6	3590	121
4000		800	37.0	29.6	3675	124
5000		800	37.0	29.6	3730	126
2700	90	800	37.0	29.6	2700	91
3000		800	37.0	29.6	2815	95
3500		800	37.0	29.6	2910	98

- Lumens maintains a tolerance of ±7% on flux measurements.
- Lumens maintains a tolerance of ±3% on forward voltage measurements.
- Lumens maintains a tolerance of ±2 on CRI measurements.

## 5. Ranks

Item	Symbol	CCT(K)	Min.	Typ.	Unit	CRI	If(mA)
Luminous Flux	$\Phi_v$	2700	2890	3200	lm	80	800
		3000	3120	3450	lm		
		3500	3230	3590	lm		
		4000	3310	3675	lm		
		5000	3350	3730	lm	90	
		2700	2430	2700	lm		
		3000	2520	2815	lm		
		3500	2620	2910	lm		
Forward Voltage	Vf	-	36.5	37.0	V	-	

- Lumens maintains a tolerance of  $\pm 7\%$  on flux measurements.
- Lumens maintains a tolerance of  $\pm 3\%$  on forward voltage measurements.
- Lumens maintains a tolerance of  $\pm 2$  on CRI measurements.

6. Chromaticity diagram & coordinates

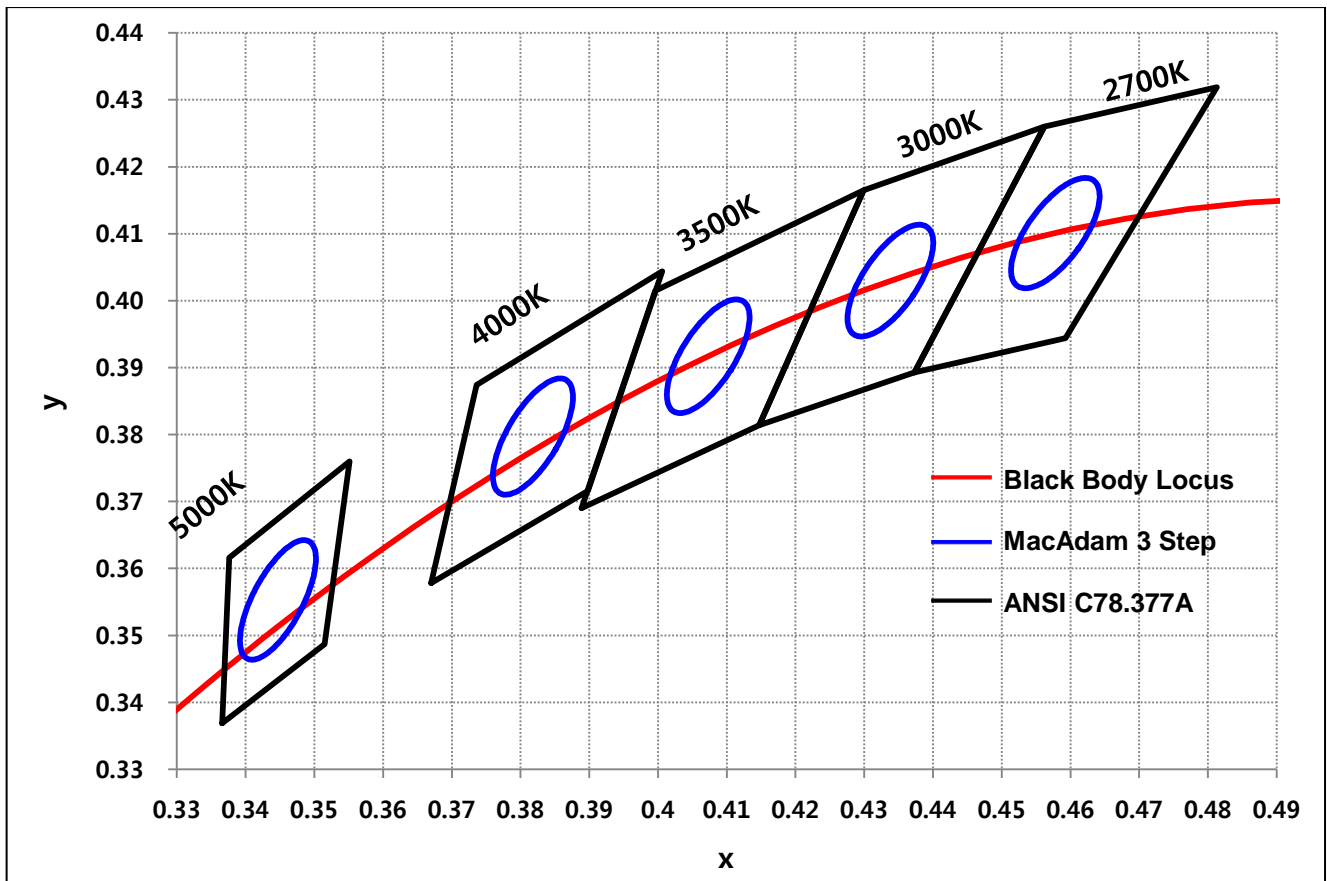

- Lumens maintains a tolerance of  $\pm 0.005$  on chromaticity (CCx, CCy)

CCT(K)	x	y	CCT(K)	x	y	CCT(K)	x	y
5000K	0.3366	0.3369	3500K	0.3889	0.3690	2700K	0.4373	0.3893
	0.3376	0.3616		0.3996	0.4015		0.4562	0.4260
	0.3551	0.3760		0.4299	0.4165		0.4813	0.4319
	0.3515	0.3487		0.4147	0.3814		0.4593	0.3944
4000K	0.3670	0.3578	3000K	0.4147	0.3814			
	0.3736	0.3874		0.4299	0.4165			
	0.4006	0.4044		0.4562	0.4260			
	0.3898	0.3716		0.4373	0.3893			

\* 3-step MacAdam Ellipse Color Definition

CCT(K)	Center		Ellipse Parameter		
	x	y	Axis a	Axis b	Angle(°)
5000K	0.3447	0.3553	0.00822	0.00354	59.6
4000K	0.3818	0.3797	0.00939	0.00402	53.7
3500K	0.4073	0.3917	0.00927	0.00414	54.0
3000K	0.4338	0.4030	0.00834	0.00408	53.2
2700K	0.4578	0.4101	0.00810	0.00420	53.7

### 7. Characteristic Graphs(Ta=25°C)

(1) Typical Forward Current vs. Forward Voltage

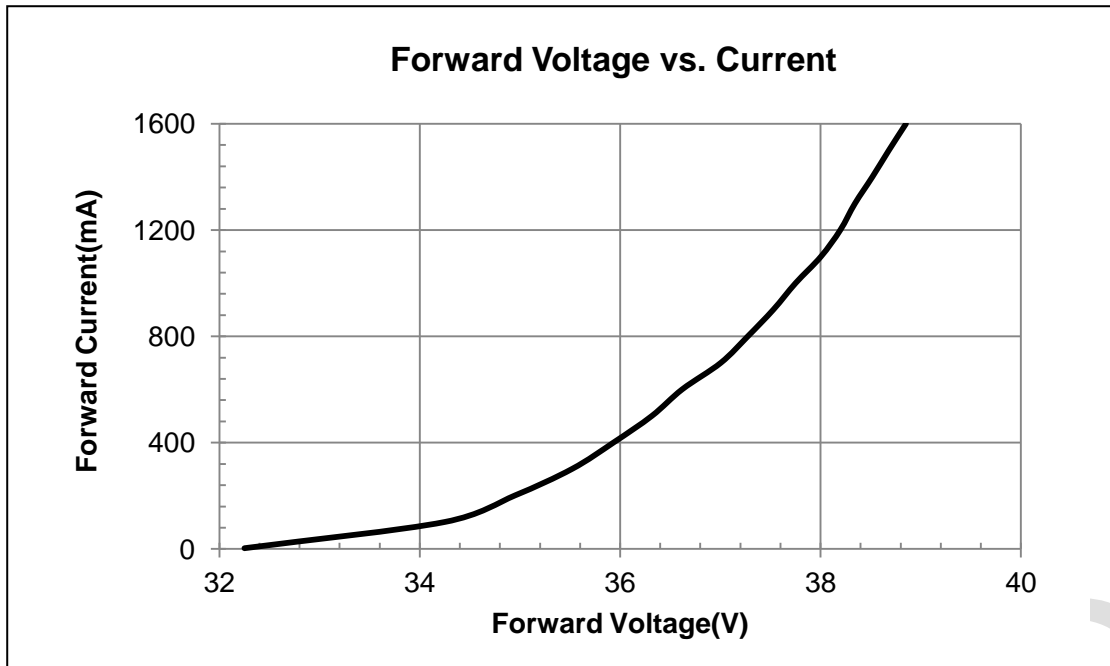

(2) Typical Relative Luminous Flux vs. Forward Current

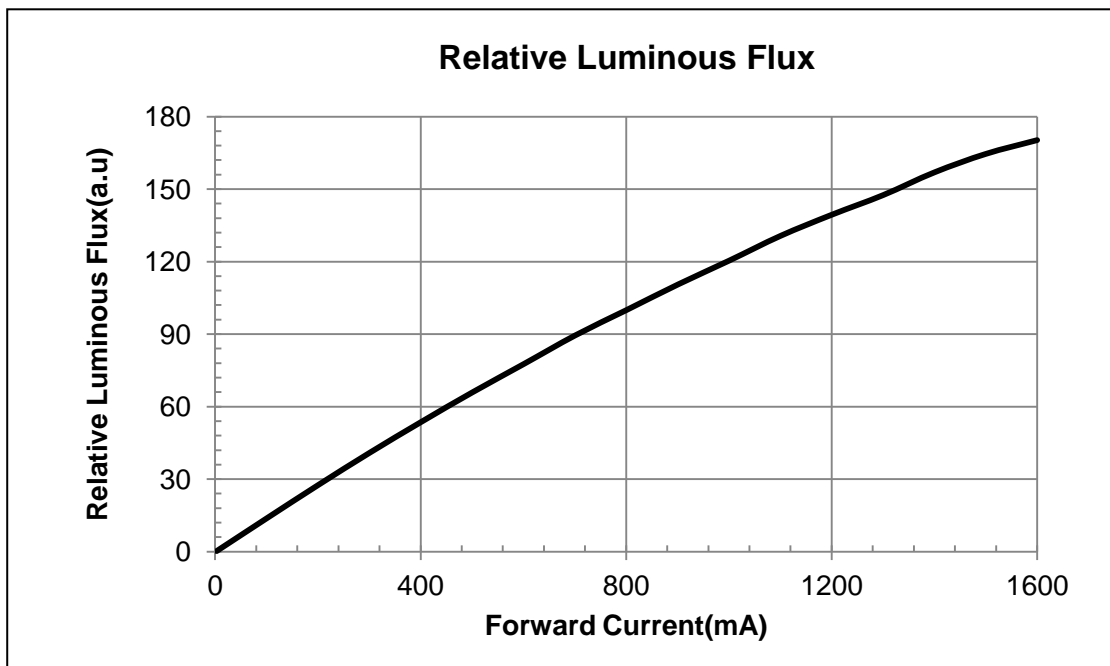

(3) Typical Allowable Forward Current with Ambient Temperature

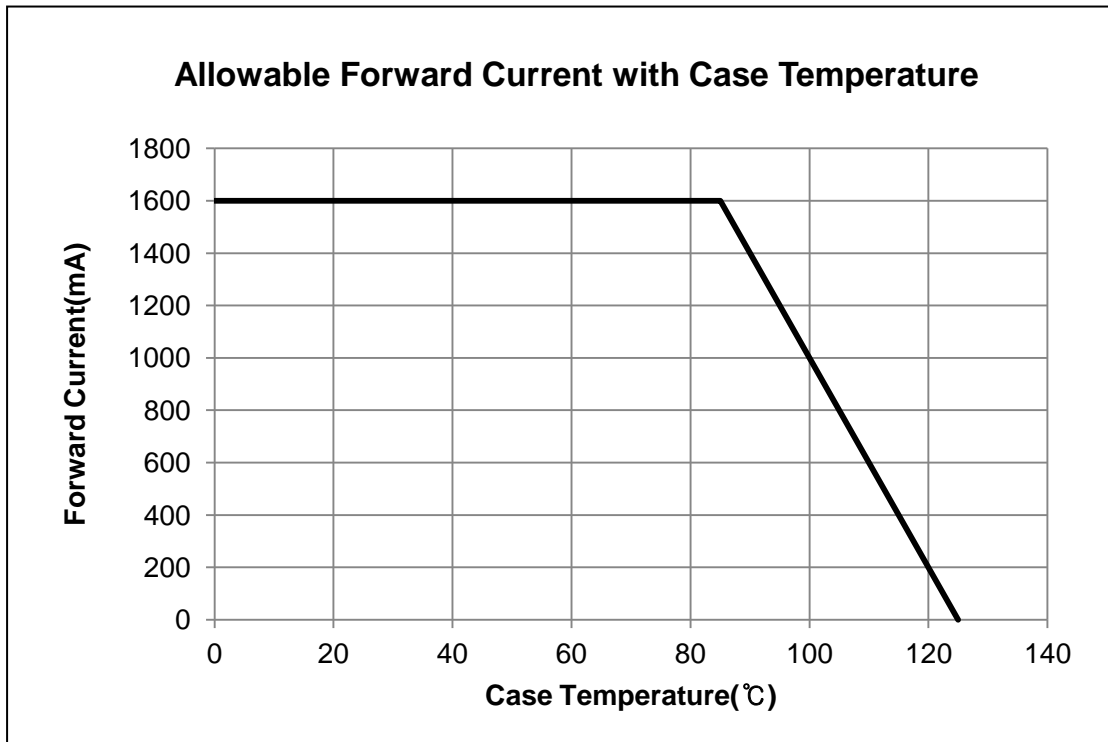

(4) Typical Spatial Radiation Characteristic

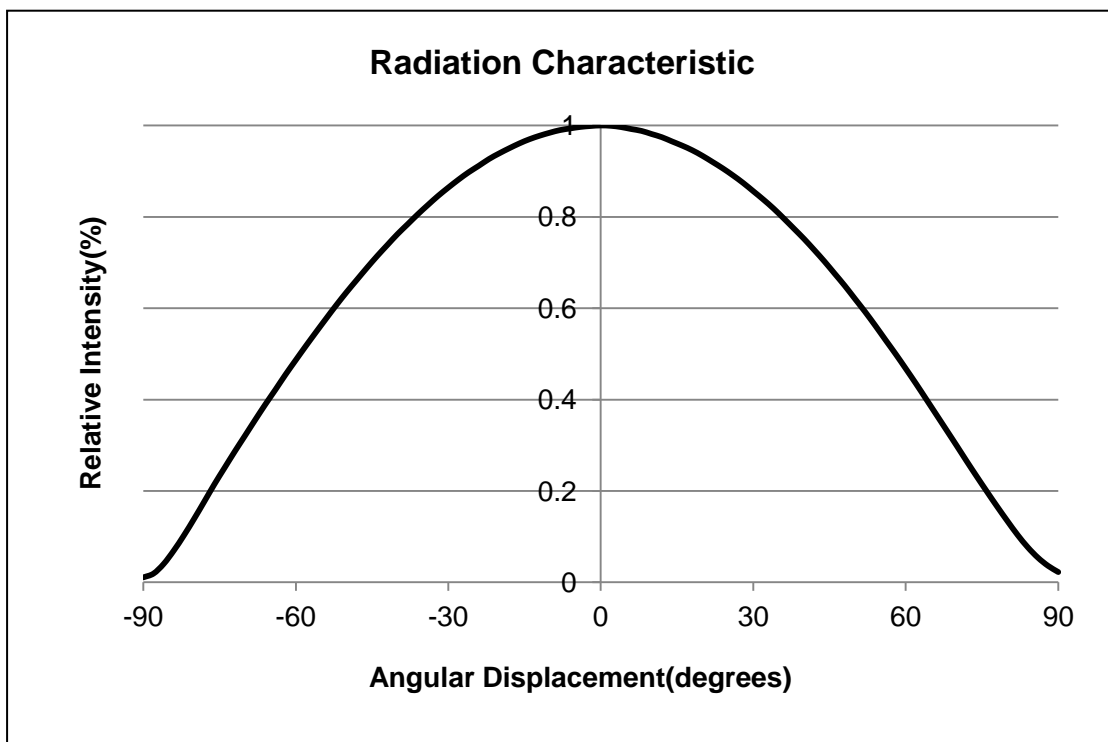



(5) Spectrum

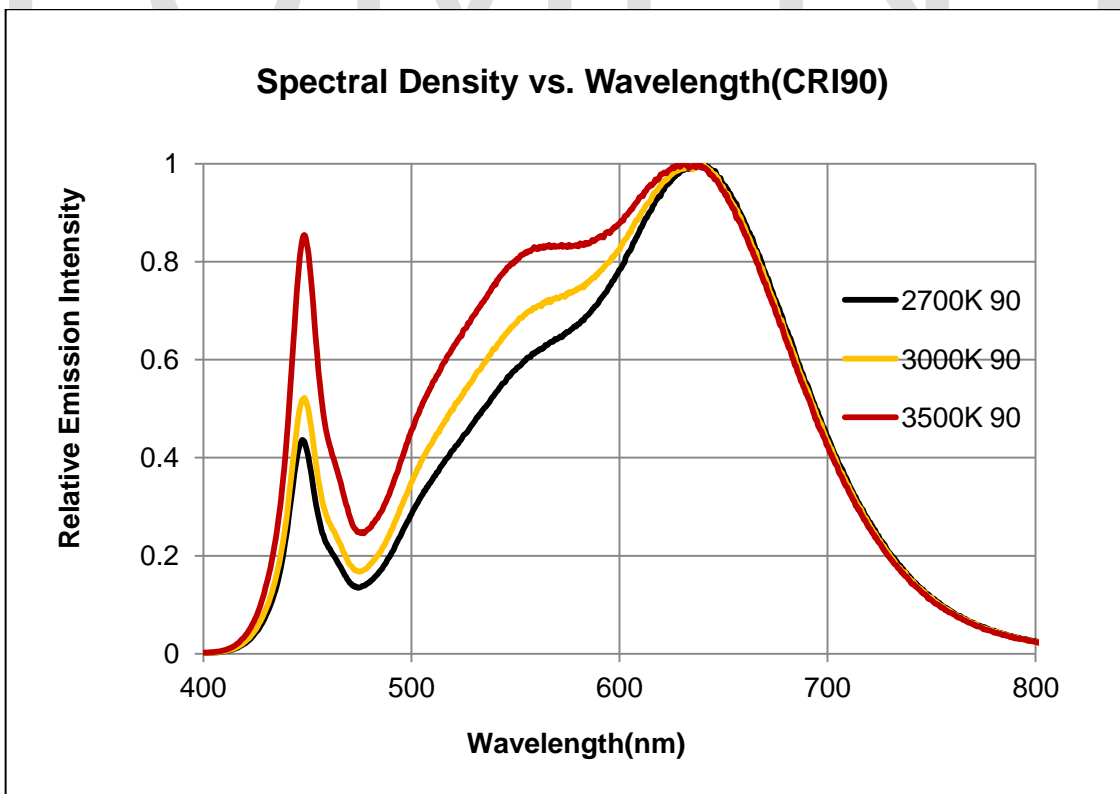
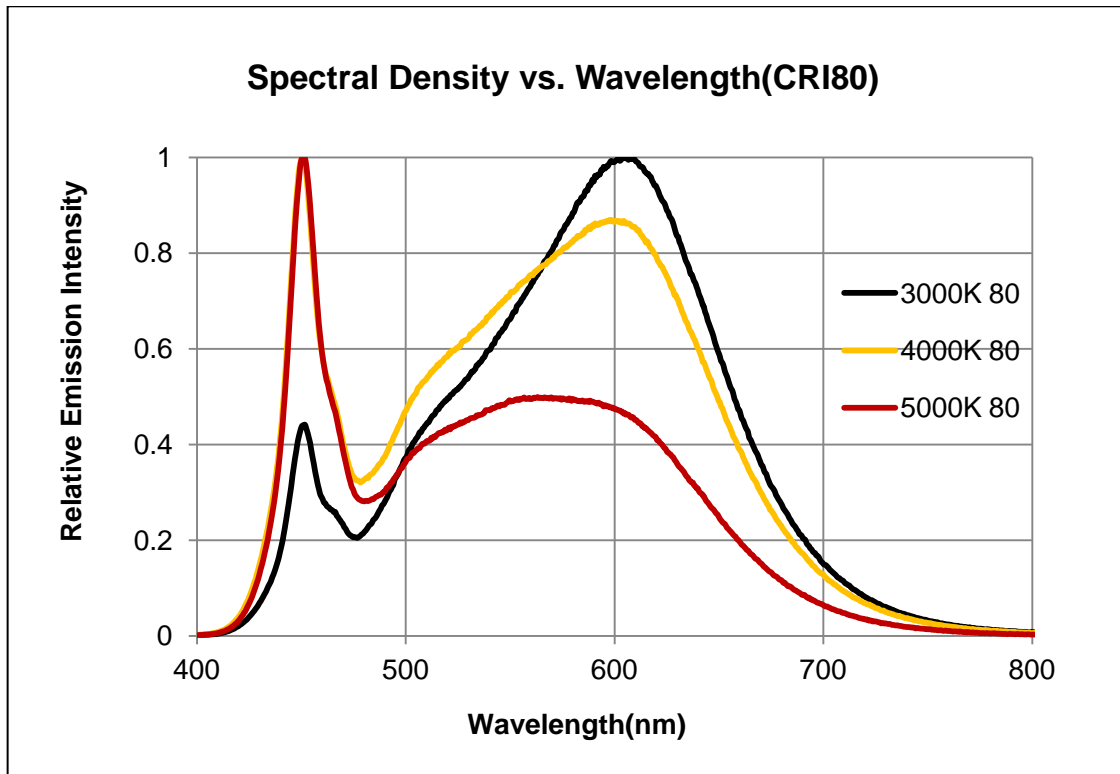

### 8. Outline Dimensions

- Package outline (Width x Length x Height) of 23.85 x 23.85 x 2.35mm
- Undefined tolerance is  $\pm 0.2$  mm

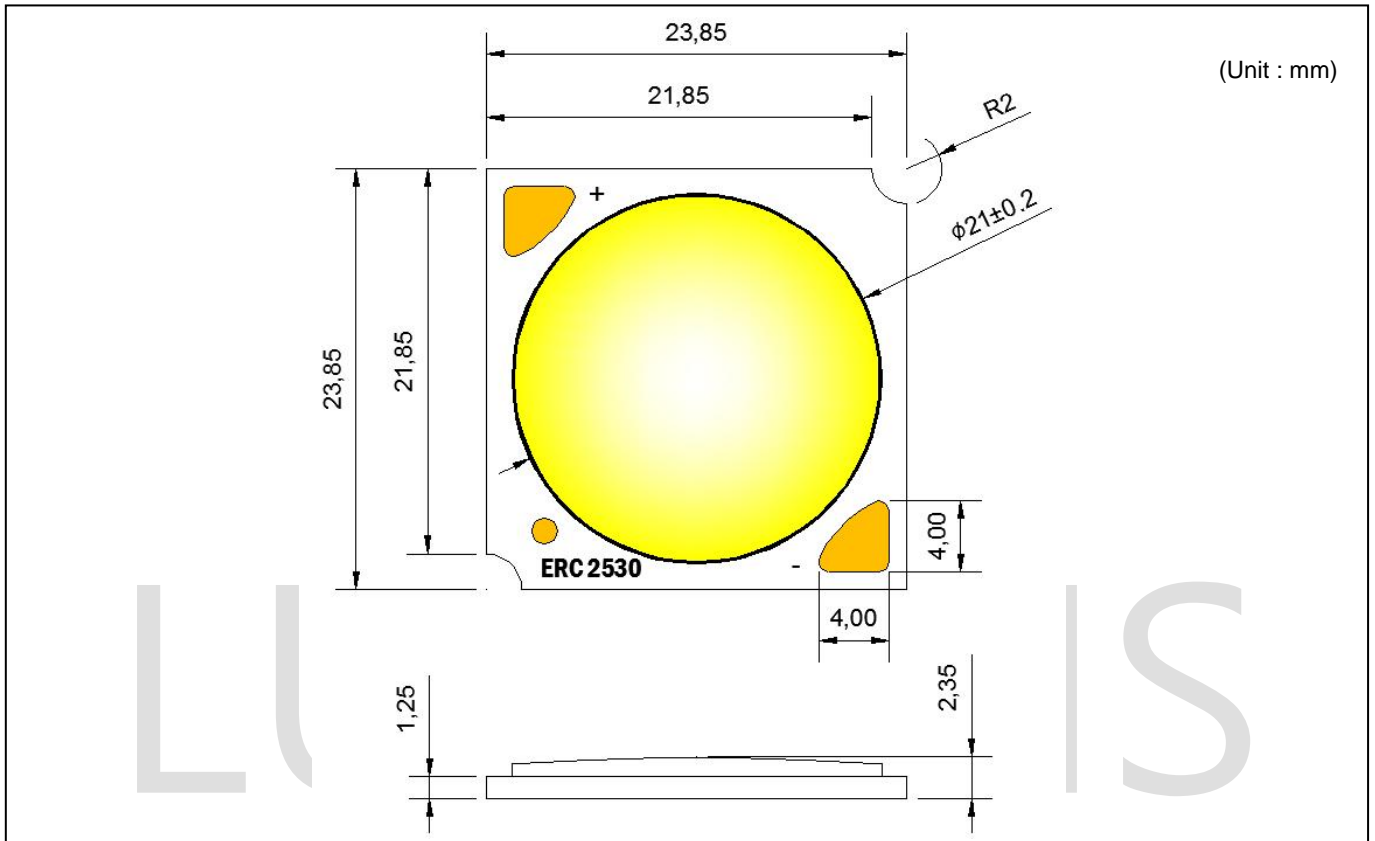

### 9. Circuit Design

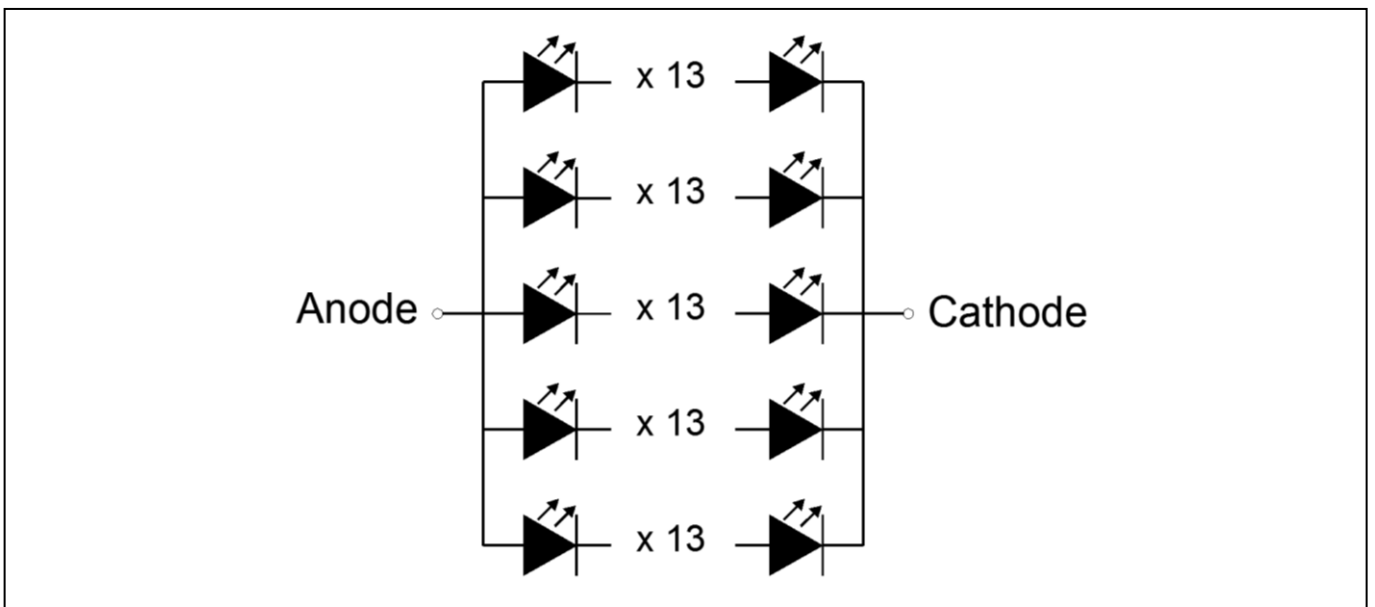

## 10. Reliability test items and conditions

Item	Reference	Test Conditions	Duration Cycle
Thermal Shock	EIAJ ED-4701	Ta = - 40°C (30min) ~ 100°C (30min)	100 Cycle
Operating Endurance Test	Internal Reference	Ta =25°C, IF = 800mA	1000 Hours
High Temperature High Humidity Life Test	Internal Reference	85°C, 85% RH	500 Hours
Low Temperature Storage Test	Internal Reference	Ta = -40°C	1000 Hours
High Temperature Storage Test	Internal Reference	Ta = 100°C	1000 Hours

### (1) Criteria for judging the damage

Item	Symbol	Condition	Criteria for Judgment	
			MIN	MAX
Forward Voltage	Vf	If = 800mA	-	USL (1) × 1.1
Luminous Intensity	Φv	If = 800mA	LSL (2) × 0.7	-

- USL : Upper Standard Level
- LSL : Lower Standard Level

## 11. Cautions

### (1) Moisture-Proof Package

- 1.1 When moisture is absorbed into the LED package it may vaporize and expand products during soldering. There is a possibility that this may cause exfoliation of the contacts and damage to the optical characteristics of the LEDs. For this reason, the moisture-proof package is used to keep moisture to a minimum in the package.
- 1.2 A package of a moisture-absorbent material (silica gel) is inserted into the shielding bag. The silica gel changes its color from blue to pink as it absorbs moisture.

### (2) Current limiting

A resistor should be used to limit current spikes that can be caused by voltage fluctuations. Otherwise damage could occur.

### (3) Storage Conditions

- 3.1 Before opening the package: The LEDs should be kept at 30°C or less and 90%RH or less. The LEDs should be used within a year. When storing the LEDs, moisture-proof packaging with moisture-absorbent material (silica gel) is recommended.
- 3.2 After opening the package: The LEDs should be kept at 30°C or less and 70%RH or less. The LEDs should be soldered within 168 hours (7 days) after opening the package. If unused LEDs remain, they should be stored in moisture-proof packages, such as sealed containers with packages of moisture-absorbent material (silica gel). It is also recommended to return the LEDs to the original moisture-proof bag and to reseal the moisture-proof bag again.
- 3.3 If the moisture-absorbent material (silica gel) has faded away or the LEDs have exceeded the recommended storage time, baking treatment should be performed using the following conditions.  
Baking treatment: more than 24 hours at 65±5°C
- 3.4 Lumens LED electrode sections are comprised of a silver-plated copper alloy. The silver surface may be affected by environments which contain corrosive gases and so on. Please avoid condition which may cause difficulty environments during soldering operations. It is recommended that the user uses the LEDs as soon as possible.
- 3.5 Please avoid rapid transitions in ambient temperature, especially in high humidity environments where condensation can occur.

### (4) Handling of Silicone (Lens) LEDs

- 4.1 Avoid silicone resin parts especially with sharp tools such as tweezers.
- 4.2 Avoid leaving fingerprints on silicone lens part.

(5) Usage

5.1 Do not exceed the values given in this specification.

LUMENS

**NOTE :**

All the information published is considered to be reliable. However, Lumens does not assume any liability arising out of the application or use of any product described herein.

Lumens reserves the right to make changes at any time without notice to any products in order to improve reliability, function or design.

Lumens products are not authorized for use as critical components in life support devices or systems without the express written approval from the managing director of Lumens.